



**TM 506/RTM 506  
POWER MODULE**

INSTRUCTION MANUAL

Tektronix, Inc.  
P.O. Box 500  
Beaverton, Oregon 97077

Serial Number \_\_\_\_\_

## WARRANTY

Tektronix warrants that this product is free from defects in materials and workmanship. The warranty period is one (1) year from the date of shipment. Tektronix will, at its option, repair or replace the product if Tektronix determines it is defective within the warranty period and if it is returned, freight prepaid, to a service center designated by Tektronix.

Tektronix is not obligated to furnish service under this warranty:

- a. to repair damage resulting from attempts by personnel other than Tektronix representatives to install, repair, or service the product;
- b. to repair damage resulting from improper use or from connecting the product to incompatible equipment;
- c. if personnel other than Tektronix representatives modify the hardware or software.

**There is no implied warranty of fitness for a particular purpose. Tektronix is not liable for consequential damages.**

Copyright © 1974, 1980 Tektronix, Inc. All rights reserved. Contents of this publication may not be reproduced in any form without the written permission of Tektronix, Inc.

Products of Tektronix, Inc. and its subsidiaries are covered by U.S. and foreign patents and/or pending patents.

TEKTRONIX, TEK, SCOPE-MOBILE, and  are registered trademarks of Tektronix, Inc.

Printed in U.S.A. Specification and price change privileges are reserved.

## GARANTIE

Les appareils TEKTRONIX sont garantis contre tout défaut de matière ou vice de fabrication, pour une durée d'une année, à compter du jour de livraison. Durant cette période, les pièces défectueuses sont remplacées, TEKTRONIX se réservant la décision de procéder soit à la réparation soit au remplacement du produit. En cas de retour du matériel à un centre désigné par Tektronix, le transport aller est à la charge du client.

TEKTRONIX n'est pas tenu de faire jouer sa garantie dans les cas suivants :

- a. réparation résultant d'interventions effectuées par une personne ne représentant pas Tektronix et visant à installer, réparer ou effectuer la maintenance de l'appareil
- b. réparation nécessitée par une utilisation impropre de l'appareil ou un couplage à un équipement incompatible
- c. modification de l'appareil ou du logiciel qui lui est propre par une personne ne représentant pas Tektronix.

**Il n'y a pas de garantie implicite de l'adaptation à une application particulière. TEKTRONIX n'est pas responsable des dommages résultants.**

Copyright © 1974, 1980 TEKTRONIX INC. Tous droits réservés. Le contenu de ce manuel ne peut être reproduit sous quelque forme que ce soit sans l'accord de Tektronix Inc.

Tous les produits TEKTRONIX sont brevetés US et Etranger et les logotypes TEKTRONIX, TEK SCOPE MOBILE,  sont déposés.

Imprimé aux USA. TEKTRONIX se réserve le droit de modifier : caractéristiques et prix dans le cadre de développements technologiques.

## GARANTIE

Tektronix gibt dem Käufer auf dieses Gerät, daß sich in einwandfreiem Zustand befindet, eine einjährige Garantie bei sachgemäßer Behandlung. Die Garantiezeit beginnt mit dem Tag der Verschiffung. Tektronix repariert oder ersetzt dieses Gerät, wenn eine einwandfreie Fehlerbestimmung durch Tektronix innerhalb der Garantiezeit vorliegt und es frachtfrei an das nächste Tektronix-Service-Center geschickt wird.

Tektronix ist nicht verpflichtet, den Service unter folgenden Bedingungen auf Garantie auszuführen:

- a. Reparaturen, die auf die Beschädigung beim Einbau, bei Reparaturen oder beim Service durch Personen verursacht wurden, die nicht zu Tektronix gehören;
- b. Reparaturen, die auf Grund von unsachgemäßer Behandlung oder durch falsche Anschlüsse erforderlich sind;
- c. wenn Personen, die nicht zu Tektronix gehören, die Hardware oder Software modifizieren.

**Es gibt keine Garantie, daß sich das Gerät für einen ganz bestimmten Zweck eignet. Tektronix kann nicht haftbar gemacht werden für Folgeschäden.**

Copyright © 1974, 1980 durch Tektronix, Inc. Alle Rechte vorbehalten. Der Inhalt dieser Publikation darf ohne Genehmigung von Tektronix, Inc. nicht weitergegeben werden.

Produkte von Tektronix, Inc. und seinen Tochtergesellschaften sind durch US- und Auslandspatente und/oder schwebende Patente abgedeckt.

TEKTRONIX, TEK, SCOPE-MOBILE und  sind geschützte Warenzeichen von Tektronix, Inc.

Gedruckt in U.S.A. Spezifikations- und Preisänderungen bleiben vorbehalten.

## 保 障

保障期間はソニー・テクトロニクス社出荷後1年間で、通常の使用にて、当社の部品又は製造技術に起因する故障は無償で修理いたします。

特殊な目的の為に改造及び改造によって起こる損害については保障いたしません。

© 1974, 1980 年著作権所有テクトロニクス社。不許複製

TEKTRONIX、TEK、SCOPE-MOBILE、 はテクトロニクス社の登録商標です。

米国にて印刷。仕様及び価格は予告なく変更する場合があります。

# TABLE OF CONTENTS

	<b>Page</b>
LIST OF ILLUSTRATIONS .....	ii
LIST OF TABLES .....	iii
OPERATORS SAFETY SUMMARY .....	iv
SERVICE SAFETY SUMMARY .....	v

## OPERATORS PART

### OPERATORS PART—ENGLISH

<b>Section 1 SPECIFICATION</b> .....	1-1
INTRODUCTION .....	1-1
ELECTRICAL CHARACTERISTICS	1-1
PHYSICAL CHARACTERISTICS ..	1-3
<b>Section 2 OPERATING INSTRUCTIONS</b> .....	2-1
GENERAL .....	2-1
BUILDING A SYSTEM .....	2-2
INSTALLATION AND PRE-TURN ON PROCEDURE .....	2-3

### OPERATORS PART—FRENCH

<b>CHAPITRE 2 INSTRUCTIONS D'UTILISATION</b>	
Généralités .....	2-1
Conception d'un système .....	2-1
Installation et procédure de mise en route .....	2-3

### OPERATORS PART—GERMAN

	<b>Seite</b>
<b>Kapitel 2 BEDIENUNGSANLEITUNG</b>	
Allgemeines .....	2-1
Aufbau eines Meßsystems .....	2-2
Einbau und Anleitung vor der Inbetriebnahme .....	2-3

### OPERATORS PART—JAPANESE

第2章 取扱説明	
はじめに .....	2-1
システム構成 .....	2-2
取付けおよび電源投入の手順 .....	2-3

**WARNING**

*THE FOLLOWING SERVICING INSTRUCTIONS ARE FOR USE BY QUALIFIED PERSONNEL ONLY. TO AVOID PERSONAL INJURY, DO NOT PERFORM ANY SERVICING OTHER THAN THAT CONTAINED IN OPERATING INSTRUCTIONS UNLESS YOU ARE QUALIFIED TO DO SO.*

## SERVICE PART

	<b>Page</b>
<b>Section 3 MAINTENANCE</b> .....	3-1
GENERAL .....	3-1
TROUBLESHOOTING AIDS .....	3-2
TROUBLESHOOTING TECHNIQUES .....	3-2
PARTS ORDERING AND REPLACING .....	3-4
INSTALLATION PROCEDURE ...	3-9
<b>Section 4 OPTIONS</b> .....	4-1
<b>Section 5 REPLACEABLE ELECTRICAL PARTS</b>	5-1
<b>Section 6 DIAGRAMS AND CIRCUIT BOARD ILLUSTRATIONS</b>	
<b>Section 7 REPLACEABLE MECHANICAL PARTS CHANGE INFORMATION</b>	7-1

# LIST OF ILLUSTRATIONS

Figure	Page
	TM 506/RTM 506 Power Module . . . . . vi
2-1	Interface Board . . . . . 2-2
2-2	Rackmounting Detail . . . . . 2-4
2-3	Dimensional Diagram . . . . . 2-3
3-1	Semiconductor Lead Configuration . . . . . 3-5
3-2	Light-Emitting Diode (LED) Lead Orientation . . . . . 3-2
3-3	220 V Selector Block In Service . . . . . 3-9
3-4	120 V Selector Block In Service . . . . . 3-9
3-5	Primary Taps Locations . . . . . 3-9
3-6	Line Voltage Set Indicator . . . . . 3-6

# LIST OF TABLES

Table	Page
1-1	Supplies . . . . . 1-1
1-2	Series Pass Transistors . . . . . 1-2
1-3	Source Power Requirements . . . . . 1-3
1-4	Miscellaneous . . . . . 1-3
1-5	Environmental . . . . . 1-3
1-6	Mechanical . . . . . 1-4
3-1	Relative Susceptibility To Static Discharge Damage . . . . . 3-6
3-2	Universal Transformer Regulating Ranges 3-9

# OPERATORS SAFETY SUMMARY

The general safety information in this part of the summary is for both operating and servicing personnel. Specific warnings and cautions will be found throughout the manual where they apply, but may not appear in this summary.

## TERMS

### In This Manual

CAUTION statements identify conditions or practices that could result in damage to the equipment or other property.

WARNING statements identify conditions or practices that could result in personal injury or loss of life.

### As Marked on Equipment

CAUTION indicates a personal injury hazard not immediately accessible as one reads the marking, or a hazard to property including the equipment itself.

DANGER indicates a personal injury hazard immediately accessible as one reads the marking.

## SYMBOLS

### In This Manual



This symbol indicates where applicable cautionary or other information is to be found.

### As Marked on Equipment



DANGER — High voltage.



Protective ground (earth) terminal.



ATTENTION — refer to manual.

### Power Source

This product is intended to operate from a power source that will not apply more than 250 volts rms between the supply conductors or between either supply conductor and ground. A protective ground connection by way of the grounding conductor in the power cord is essential for safe operation.

### Grounding the Product

This product is grounded through the grounding conductor of the power cord. To avoid electrical shock, plug the

power cord into a properly wired receptacle before connecting to the product input or output terminals. A protective ground connection by way of the grounding conductor in the power cord is essential for safe operation.

### Danger Arising From Loss of Ground

Upon loss of the protective-ground connection, all accessible conductive parts (including knobs and controls that may appear to be insulating) can render an electric shock.

### Use the Proper Power Cord

Use only the power cord and connector specified for your product.

Use only a power cord that is in good condition.

For detailed information on power cords and connectors, see maintenance section.

Refer cord and connector changes to qualified service personnel.

### Use the Proper Fuse

To avoid fire hazard, use only the fuse of correct type, voltage rating and current rating as specified in the parts list for your product.

Refer fuse replacement to qualified service personnel.

### Do Not Operate in Explosive Atmospheres

To avoid explosion, do not operate this product in an explosive atmosphere unless it has been specifically certified for such operation.

### Do Not Remove Covers or Panels

To avoid personal injury, do not remove the product covers or panels. Do not operate the product without the covers and panels properly installed.

### Do Not Operate Without Covers (for TM 500 plug-ins only)

To avoid personal injury, do not operate this product without covers or panels installed. Do not apply power to the plug-in via a plug-in extender.

# **SERVICE SAFETY SUMMARY**

## *FOR QUALIFIED SERVICE PERSONNEL ONLY*

*Refer also to the preceding Operators Safety Summary.*

### **Do Not Service Alone**

Do not perform internal service or adjustment of this product unless another person capable of rendering first aid and resuscitation is present.

### **Use Care When Servicing With Power On**

Dangerous voltages exist at several points in this product. To avoid personal injury, do not touch exposed connections and components while power is on.

Disconnect power before removing protective panels, soldering, or replacing components.

### **Power Source**

This product is intended to operate from a power source that will not apply more than 250 volts rms between the supply conductors or between either supply conductor and ground. A protective ground connection by way of the grounding conductor in the power cord is essential for safe operation.

# CONSIGNES DE SECURITE

Ce rappel des consignes générales de sécurité s'adresse à la fois aux utilisateurs et au personnel de maintenance. Avertissements et précautions à respecter sont annotés au long de ce manuel à chaque fois que l'utilisation du TM 506 l'exige. Il est à noter que ceux-ci peuvent ne pas figurer dans cette rubrique de rappel.

## TERMES

### Dans ce manuel

Les paragraphes intitulés ATTENTION identifient les circonstances ou opérations pouvant entraîner la détérioration de l'appareil ou de tout autre équipement.

Les paragraphes intitulés AVERTISSEMENT indiquent les circonstances dangereuses pour l'utilisateur (danger de mort ou risque de blessure).

### Repères gravés sur l'appareil

CAUTION (ATTENTION) : ce mot identifie les zones de risque non immédiatement perceptibles ou un risque éventuel de détérioration de l'appareil.

DANGER (DANGER) : ce mot identifie les zones de risque immédiat pouvant entraîner blessures ou mort.

## SYMBOLES

### Dans ce manuel



Ce symbole signifie (se reporter au manuel).

### Gravés sur l'appareil



DANGER – Haute tension



Borne de masse de protection (terre)



ATTENTION – se reporter au manuel

### Source d'alimentation

L'appareil est conçu pour fonctionner à partir d'une source d'alimentation maximale de 250 V efficaces entre les conducteurs d'alimentation ou entre chaque conducteur d'alimentation et la terre. Pour utiliser l'appareil en toute sécurité, une connexion à la masse, réalisée au moyen d'un conducteur prévu dans le cordon d'alimentation, est indispensable.

# CONSIGNES DE SECURITE

## *UNIQUEMENT DESTINEES AU PERSONNEL DE MAINTENANCE*

Ces consignes s'adressent exclusivement à un personnel qualifié. Il est également indispensable de se reporter aux consignes de sécurité précédentes.

### **Ne pas se servir de l'appareil seul**

Toute intervention interne ou réglage doit s'effectuer en présence d'une autre personne capable d'assurer les premiers secours en cas de danger.

### **Agir avec précaution lorsque l'appareil est sous tension**

Des potentiels dangereux existent en différents points de l'appareil. Pour éviter toute blessure, ne pas intervenir sur les connexions et les composants alors que l'appareil est sous tension. Débrancher l'alimentation avant le démontage des panneaux, soudure ou remplacement de composants.

### **Source d'alimentation**

Cet appareil est conçu pour fonctionner à partir d'une source d'alimentation qui n'applique pas plus de 250 V efficaces entre les conducteurs d'alimentation ou entre un conducteur et la masse. Pour utiliser l'appareil en toute sécurité, une connexion à la masse réalisée au moyen d'un conducteur prévu dans le cordon d'alimentation est indispensable.



**Mise à la masse de l'appareil**

Une fois installé dans le châssis d'alimentation, l'appareil est relié à la masse à l'aide d'un conducteur du cordon d'alimentation. Pour éviter tout choc électrique, insérer la prise du cordon d'alimentation dans une prise de distribution correspondante avant de connecter l'entrée ou les sorties de l'appareil. Pour utiliser l'appareil en toute sécurité, une connexion à la masse, réalisée au moyen d'un conducteur prévu dans le cordon d'alimentation, est indispensable.

**Danger provoqué par la coupure de connexion de masse**

En cas de coupure de la connexion de masse, tous les éléments conducteurs accessibles (y compris boutons et commandes apparaissant isolants) peuvent provoquer un choc électrique.

**Utiliser le cordon d'alimentation approprié**

N'utiliser que le cordon d'alimentation et la prise recommandés pour votre appareil.

Utiliser un cordon d'alimentation en parfait état.

Pour toute information détaillée concernant cordons et prises d'alimentation, se reporter au chapitre «Maintenance» du manuel en Anglais.

Seul, un personnel qualifié peut procéder à un changement de cordon et prises.

**Utiliser le fusible approprié**

Pour éviter tout risque d'accident (incendie...) n'utiliser que le fusible recommandé pour votre appareil.

Le fusible de remplacement doit toujours correspondre au fusible remplacé : même type, même tension et même courant. Un remplacement de fusible ne doit être effectué que par un personnel qualifié.

**Ne pas utiliser l'appareil en atmosphères explosives**

Pour éviter toute explosion, ne pas utiliser cet appareil dans une atmosphère de gaz explosifs.

**Ne pas démonter les capots ou les panneaux**

Pour éviter toute blessure, ne pas ôter les capots ou les panneaux. N'utiliser l'appareil que si ceux-ci ont été correctement remis en place.

**Ne pas utiliser l'appareil sans les capots de protection**

Pour éviter tout risque de blessure, ne pas utiliser cet appareil alors que les capots ou panneaux n'ont pas été installés. Ne pas appliquer les alimentations au tiroir par l'intermédiaire d'un prolongateur.

# SICHERHEITSANGABEN FÜR DEN ANWENDER

Die allgemeinen Sicherheitsinformationen in diesem Teil der Angaben dienen dem Anwender- und Servicepersonal. Spezielle Warnungen und Hinweise sind überall im Handbuch zu finden, müssen jedoch in diesen Angaben nicht erscheinen.

## BEGRIFFE

### In diesem Handbuch

**VORSICHTSHINWEISE** erläutern Bedingungen, die zur Zerstörung des Gerätes oder anderer Gegenstände führen können.

**WARNUNGSHINWEISE** erläutern Bedingungen, die zu Personenschäden führen können oder lebensgefährlich sind.

### Markierungen auf dem Gerät

**CAUTION – VORSICHT** weist darauf hin, daß durch zufälliges Berühren an einer nicht unmittelbar zugänglichen Stelle Personenschaden entstehen kann, oder Schaden am Gerät selbst.

**DANGER - GEFAHR** weist darauf hin, daß durch zufälliges Berühren an einer zugänglichen Stelle Personenschaden entstehen kann.

## SYMBOLE

### In diesem Handbuch



Dieses Symbol zeigt an, wo Vorsicht walten zu lassen ist, oder wo Informationen zu finden sind.

### Markierungen auf dem Gerät



GEFAHR – Hochspannung.



Schutzerdungskontakt.



ACHTUNG – beziehen Sie sich auf das Handbuch.

### Netzspannungsversorgung

Die Betriebsspannung für dieses Gerät darf 250 V<sub>eff</sub> nicht überschreiten und ist an die Versorgungsleitungen bzw. an eine Versorgungsleitung und Masse anzulegen. Innerhalb des Netzanschlußkabels muß ein Schutzleiter vorhanden sein, der mit Gerätemasse verbunden ist.

### Masseanschluß des Gerätes

Dieses Gerät wird über den Schutzleiter der Versorgungseinheit mit Erdpotential verbunden. Zur Vermeidung

von elektrischen Schlägen vor der Beschaltung der Ein- und Ausgänge ist der Netzstecker in eine korrekt verdrahtete Steckdose einzustecken. Verwenden Sie den Schutzleiter nicht als einzige Verbindung zwischen zwei oder mehreren Geräten. Zur Vermeidung von elektrischen Schlägen sind die Geräte untereinander mit separaten Leitungen zu verbinden.

### Gefahr durch fehlende Schutzerde

Durch eine fehlende Schutzerde können alle berührbaren, leitenden Teile (einschließlich Knöpfe und andere Bedienelemente, die isoliert sind) einen elektrischen Schlag bei der Berührung auslösen.

### Verwendung eines richtigen Netzkabels

Verwenden Sie nur Netzkabel, die für die Versorgungseinheit geeignet sind und die sich in gutem Zustand befinden.

Für detaillierte Informationen über Kabel und Stecker beziehen Sie sich bitte auf Abbildungen innerhalb des Handbuches.

Ein Austausch von Kabeln und Steckern ist nur von geschultem Personal vorzunehmen.

### Verwendung einer richtigen Sicherung

Zur Vermeidung von Brandschäden sind nur Sicherungen zu verwenden, die in den Teilleisten dieses Gerätes aufgeführt sind und die in Spannungs- und Stromwert entsprechend sind.

Ersatz von Sicherungen ist nur von geschultem Personal vorzunehmen.

### Arbeiten Sie nicht in explosiver Umgebung

Zur Vermeidung von Explosionen ist die Inbetriebnahme dieses Gerätes in explosiver Umgebung zu unterlassen, wenn das Gerät nicht dafür geeignet ist.

### Entfernen Sie keine Gehäuseabdeckungen

Zur Vermeidung von Personenschäden sind keine Gehäuseteile zu entfernen. Auch ist das Gerät ohne Gehäuse nicht in Betrieb zu nehmen.

### Arbeiten Sie nicht ohne Gehäuseabdeckung

Zur Vermeidung von Personenschäden ist das Gerät nicht ohne Gehäuse in Betrieb zu nehmen. Der Einschub sollte nicht über einen Verlängerungsadapter betrieben werden.

# SICHERHEITSAANGABEN FÜR DEN SERVICE

## NUR FÜR GESCHULTES PERSONAL

*Beziehen Sie sich auch auf die vorangehenden Sicherheitsangaben für den Anwender.*

### **Führen Sie keine Servicetätigkeiten alleine durch**

Nehmen Sie an dem Gerät keine Service- oder Einstellarbeiten vor, wenn nicht eine andere Person verfügbar ist, um im Bedarfsfall Erste Hilfe oder Wiederbelebungsversuche zu leisten.

### **Lassen Sie besondere Vorsicht walten, wenn Sie an einem unter Spannung stehenden Gerät arbeiten**

An verschiedenen Stellen im Gerät liegen hohe und damit gefährliche Spannungen. Zur Vermeidung von Personen-

schäden sind solche Stellen und Bauteile nicht zu berühren, während Betriebsspannung anliegt.

Vor dem Entfernen von Gehäuseteilen, Löten oder Ersetzen von Bauteilen ist immer die Betriebsspannung zu entfernen.

### **Netzspannungsversorgung**

Die Betriebsspannung für dieses Gerät darf  $250 V_{\text{eff}}$  nicht überschreiten und ist an die Versorgungsleitungen bzw. an eine Versorgungsleitung und Masse anzulegen. Innerhalb des Netzanschlußkabels muß ein Schutzleiter vorhanden sein, der mit Gerätemasse verbunden ist.

# ご使用の前に

この章では操作する方およびサービス・エンジニアの方に安全にお取扱いいただくための注意事項が述べられています。

## 用語

### マニュアル中の用語

**注意**の項は本機器または他の接続機器に損傷を及ぼす恐れのある場合の注意です。

**警告**の項は人体に損傷を与えたり生命に危険を及ぼす恐れのある場合の注意です。

### 機器上に記されている用語

CAUTIONは人体および本機器または周辺機器に損傷を及ぼす恐れがある部分を示しています。

DANGERは人体に損傷を及ぼしたり生命に危険を与える恐れがある部分を示しています。

## 記号

### この取扱説明書に出てくる記号



このマークは適切な注意、または他の項目を参照する必要がある場合を指示しています。

### 機器に記された記号



危険——高電圧



保護用接地ターミナル



注意——取扱説明書参照

## 電源

本機器は電源コードの線間、あるいは電源コードとグラウンド間が250Vrms以内の範囲の電源で作動します。安全のために電源コードのアース線で接地して下さい。

## 機器の接地

本機器は電源コードのアース線で接地されます。電氣的ショックを避けるために、電源コードをコンセントに差し込んでから、機器の入、出力端子への接続を行って下さい。

電源コードの接地線を用いて接地を行うと安全です。

## 接地を行わない場合

接地が行われていないと、導体の部品（絶縁処理されたノブおよびコントロールつまみを含む）により電氣的ショックを受けることもあります。

## 電源コード

製品に適合した電源コードをご使用下さい。

故障のない電源コードをご使用下さい。

電源コードおよびコネクタに関する詳細はメンテナンスの章をご覧ください。

コードまたはコネクタの交換に際しては当社エンジニアにおたずね下さい。

## ヒューズ

危険防止のため、マニュアルに記載されている仕様に適合するヒューズをご使用下さい。

ヒューズの交換に関する詳細は、当社フィールド・エンジニアにおたずね下さい。

## 爆発防止

危険防止のため、爆発性のガスが周囲にあるような所では作動させないで下さい。

## カバー、パネルについて

プラグインのカバーやパネルを取りはずしたまま作動させないで下さい。

## 機器使用に際して

人体への危険を防止するため、カバーやパネルを取りはずしたまま作動させないで下さい。またプラグイン・エクステンダでプラグインと電源を接続しないで下さい。

# サービス上の注意

## サービス・エンジニアの方へ

“操作上の注意”を先にお読み下さい。

### 1人でサービスを行わないで下さい。

機器の内部点検または修理は、万一の場合に備えて応急処置のできる人がいる所で行って下さい。

パネルの取りはずし、ハンダ付、部品の交換を行う前には、電源を必ず切つて下さい。

### 電源を入れた場合の注意

機器内部には高電圧の部分があります。人体への危険を防止するため、電源がはいつている時は、露出している接続部分や部品には手を触れないで下さい。

### 電源

TM506型は電源コードの線間あるいは電源コードとグラウンド間が250Vrms以内の範囲の電源で作動します。安全のために電源コードのアース線できちんと接地して下さい。



# SPECIFICATION

## INTRODUCTION

### Description

The TM 506 is a six-wide power module compatible with all TM 500 plug-ins. It provides unregulated dc and ac supplies and non-dedicated power transistors for plug-in usage. It features a high-power compartment for special plug-ins or applications. It also has forced air cooling to

aid in maintaining proper internal operating temperature. Option 2 rear interface allows interconnection of special features between plug-ins or with external devices through the back panel.

### Performance Conditions

The values listed below are valid only when the instrument is operated at an ambient temperature between 0°C and 50°C.

## ELECTRICAL CHARACTERISTICS

Table 1-1

### SUPPLIES

Characteristics	Performance Requirements	Supplemental Information
+33.5 Vdc		+23.7 V to +40.0 V
Tolerance <sup>a</sup>		
PARD (Periodic and Random Deviation)		≤2.5 Vpp
Maximum load		350 mA
Maximum load di/dt		10 mA/μs
−33.5 Vdc		−23.7 V to −40.0 V
Tolerance <sup>a</sup>		
PARD		≤2.5 Vpp
Maximum load		350 mA
Maximum load di/dt		10 mA/μs
+11.5 Vdc <sup>b</sup>		
Tolerance <sup>a</sup>		+7.6 V to +16.0 V
PARD		≤2.5 Vpp
Maximum load		
Standard compartment		1.3 A
High-power compartment		4.0 A
Maximum load di/dt		20 mA/μs

Table 1-1 (cont)

Characteristics	Performance Requirements	Supplemental Information
25 Vac (2 each)		
Range		25.0 Vrms +10%, -15% floating
Maximum load		
Standard compartment		25 VA
High-power compartment		60 VA
Maximum floating voltage		350 V peak
17.5 Vac <sup>b</sup>		
Range		With a grounded center tap 20.5 Vrms +10%, -20%
Maximum load		
Standard compartment		30 VA
High-power compartment		95 VA
Maximum plug-in power drawn from mainframe <sup>c</sup>		
Standard compartment		35 Wdc or 75 VAac
High-power compartment		45 Wdc or 125 VAac
Combined power drawn sharing limitation <sup>c</sup>		
Standard compartment		VAac + 2.1 (Wdc) ≤ 75 VAac
High-power compartment		VAac + 2.1 (Wdc) ≤ 150 VAac
Fuse data		
+33.5 Vdc		2.5 A, 3 AG, fast blow
-33.5 Vdc		2.5 A, 3 AG, fast blow
+11.5 Vdc		7.5 A, 3 AG, fast blow
-11.5 Vdc, high power		5 A, 3 AG, slow blow

<sup>a</sup>Worst case; low line-full load and high line-no load values including PARD.

<sup>b</sup>Floating in high-power compartment, 350 V peak.

<sup>c</sup>At nominal line voltage.

Table 1-2

SERIES PASS TRANSISTORS

Characteristics	Performance Requirements	Supplemental Information
Type		One each NPN or PNP per compartment.
Maximum dissipation		
Standard compartment		7.5 W each, 15 W total
High-power compartment		30 W each, 50 W total



**Table 1-3**  
**SOURCE POWER REQUIREMENTS**

<b>Characteristics</b>	<b>Performance Requirements</b>	<b>Supplemental Information</b>
Voltage ranges		Selectable 100 V, 110 V, 120 V, 200 V, 220 V, and 240 V nominal line $\pm 10\%$
Line frequency		48 Hz to 60 Hz
Max power consumption		Approximately 320 W
Fuse data		
100 V, 110 V, 120 V ranges		4 A, 3 AG, slow blow
200 V, 220 V, 240 V ranges		2 A, 3 AG, slow blow

**Table 1-4**  
**MISCELLANEOUS**

<b>Characteristics</b>	<b>Performance Requirements</b>	<b>Supplemental Information</b>
Maximum recommended plug-in power dissipation		
One-wide		10 to 15 W
Two-wide		25 to 35 W

## PHYSICAL CHARACTERISTICS

**Table 1-5**  
**ENVIRONMENTAL<sup>a</sup>**

<b>Characteristics</b>	<b>Supplemental Information</b>
Overall	Meets or exceeds MIL-T-28800B, class 5 requirements with exception for vibration, shock, and EMC.
Temperature	
Operating	0°C to +50°C
Non-operating	-55°C to +75°C
Humidity	90-95% RH for 5 days cycled to +50°C.
Altitude	
Operating	4.6 km (15,000 ft)
Non-operating	15 km (50,000 ft)

Table 1-5 (cont)

Characteristics	Supplemental Information
Vibration	0.26 mm (0.010"), 10 Hz to 55 Hz, 75 minutes.
Shock	20 g's (1/2 sine), 11 ms, 18 shocks
Bench handling	45°, 4", or equilibrium whichever occurs first
Transportation	Qualified under National Safe Transit Association Preshipment Test Procedures 1A-B-1 and 1A-B-2.

<sup>a</sup>With plug-ins. Some plug-ins require additional limitations.

Table 1-6  
MECHANICAL

Characteristics	Supplemental Information
Net weight	
TM 506	29.0 lbs (13.2 kg)
RTM 506	32.0 lbs (14.4 kg)
Overall dimensions	
TM 506	6.0 in (15.2 cm) H, 17.4 in (44.2 cm) W, 20.0 in (40.8 cm) L
RTM 506	5.25 in (13.3 cm) H, 19.0 in (48.3 cm) W, 18.9 in (48.0 cm) L
Rack mount height (RTM 506 only)	5.75 in (14.6 cm) minimum, 7.00 inches (17.8 cm) standard spacing. At least 0.25 inch space must be provided above and below main-frame for proper cooling.

# OPERATING INSTRUCTIONS

## GENERAL

### Installation

For full installation instructions refer to the procedure at the end of this section.

### Power Source

The TM 506 is designed to operate from a power source with its neutral at or near earth (ground) potential with a separate safety-earth conductor. It is not intended for operation from two phases of a multi-phase system.

### Power Usage

With six plug-ins installed, the TM 506 may require up to 320 watts at the upper limits of high line voltage ranges. Actual power consumption depends on the particular plug-in configuration and operating modes selected.

**High Power Compartment.** Some TM 500 Series plug-in modules require high power to operate at their maximum capabilities. To meet this requirement the TM 506 has a high power compartment. When viewed from the front this compartment is on the extreme right-hand side of the unit.

**Loading Considerations.** The power capability of the TM 506 can best be used by carefully planning the plug-in configuration, the external loads, and the resulting power distributions. Optimum conditions may be obtained by:

1. Having equal loads in all compartments.
2. Dissipating as much power as possible in the external loads.
3. Operating the system in an ambient temperature near 25°C.

Each plug-in is provided access to a pair of heat-sinked, series-pass transistors, one NPN and the other PNP. These transistors enable the plug-in to operate in power ranges not possible if the power were to be dissipated in the plug-ins themselves.

### Operating Temperatures

The TM 506 can be operated in an ambient air temperature of 0°C to 50°C. Thermal cutout devices protect

the system by disconnecting the power to the TM 506 Power Module when internal temperatures rise above a safe operating level. These devices automatically return power to the unit when the internal temperatures return to a safe level.

Since the TM 506 can be stored in temperatures between  $-40^{\circ}\text{C}$  and  $+75^{\circ}\text{C}$ , allow the instrument's chassis to return to within the operating limits before applying power.

### Power Modules

It is not necessary that all the plug-in compartments be utilized in order to operate the Power Module. The only modules needed are those necessary to complete the task.



*Turn the Power Module off before inserting the plug-in; otherwise, damage may occur to the plug-in circuitry.*

### Module Installation

1. Check the location of the white plastic barrier keys on the TM 506 interconnecting jack to ensure that their locations match the slots in the edge of the plug-in module's circuit board.
2. Align the plug-in module chassis with the upper and lower guides of the selected compartment. Push the module in and press firmly to seat the circuit board in the interconnecting jack. (Remove the plug-in module by pulling on the white release latch in the lower left corner of each module.)

### Turn-on Procedure

After completing the installation procedure, found at the end of this section, and installing the plug-ins, pull the PULL ON POWER switch on the right side of the TM 506. Some plug-ins have independent power switches, usually labeled OUTPUT, controlling application of mainframe power to the plug-in. Press this button to activate the plug-in.

## BUILDING A SYSTEM

### Family Compatibility

Mechanically, the plug-in modules are very similar to other Tektronix product families. However, they are not electrically compatible. Therefore, the TM 506 interface has barriers on the mating connectors between pins 6 and 7 to ensure that incompatible modules cannot be inserted. See Fig. 2-1. A compatible module will have a matching slot between pins 6 and 7 of its main circuit board edge connector. This slot and barrier combination is the primary keying assignment.

TM 500-compatible plug-in modules are also identified by the white color of the release latch.

### Customizing the Interface

The modularity of this instrumentation system provides for many different functions to be performed by the plug-in modules. Specific functions are grouped into families or classes, of which there may be several plug-in module members. For instance, some classes are Power Supplies, Signal Sources, Measurement, and so forth. Each modular member of a functional family will have a second slot peculiar to its family assignment located in its edge connector. The TM 506 user can "program" one or more compartments to accept only members of that family by installing a second barrier in the interface connector to match the module's slot location. An entire TM 506 can be "programmed" in this manner to set up instruction systems for specific work functions. For extra barriers, order Tektronix Part No. 214-1593-02.

Jumper wires can be used to further specialize the interface. Compartments can be made to "talk" to each other by connecting jumpers on the back side of the interface board, using pins 14 through 28 (A-side and B-side both) of the interconnecting jacks. See the following description of Option 2. Refer to each plug-in module's Manual for the I/O assignments of each pin at the rear interface. Once having made interconnections of a specialized nature, it is recommended that barriers be installed on the interconnecting jacks to ensure module compatibility with the customized wiring.

### Rear Panel

The rear subpanel has a connector mounting plate for BNC and multi-pin connector mountings. Customer or factory-installed connectors and wiring (see following description of Option 2) could provide external access to the interface for external I/O control. This feature makes the TM 500 Series Modular Instrumentation System very flexible in bench-top or rackmounted systems.

**Option 2.** This factory-installed option adds 25-mil square-pin connectors to the rear of the interconnecting jacks at all pin locations from pins 14A and B through pins 28A and B. This will keep the interface flexible by making it easy and fast to change customized wiring using prepared wires with square-pin receptacles and long-nose pliers or tweezers. It also protects the circuit board from damage by repeated soldering and unsoldering of jumper wires. This option also adds six BNC connectors and one 50-pin connector to the rear panel. These connectors are not pre-wired. Instead, prepared jumpers, coaxial cables, and interconnection jack barriers are included in a kit. This gives a system designer as much flexibility as possible.

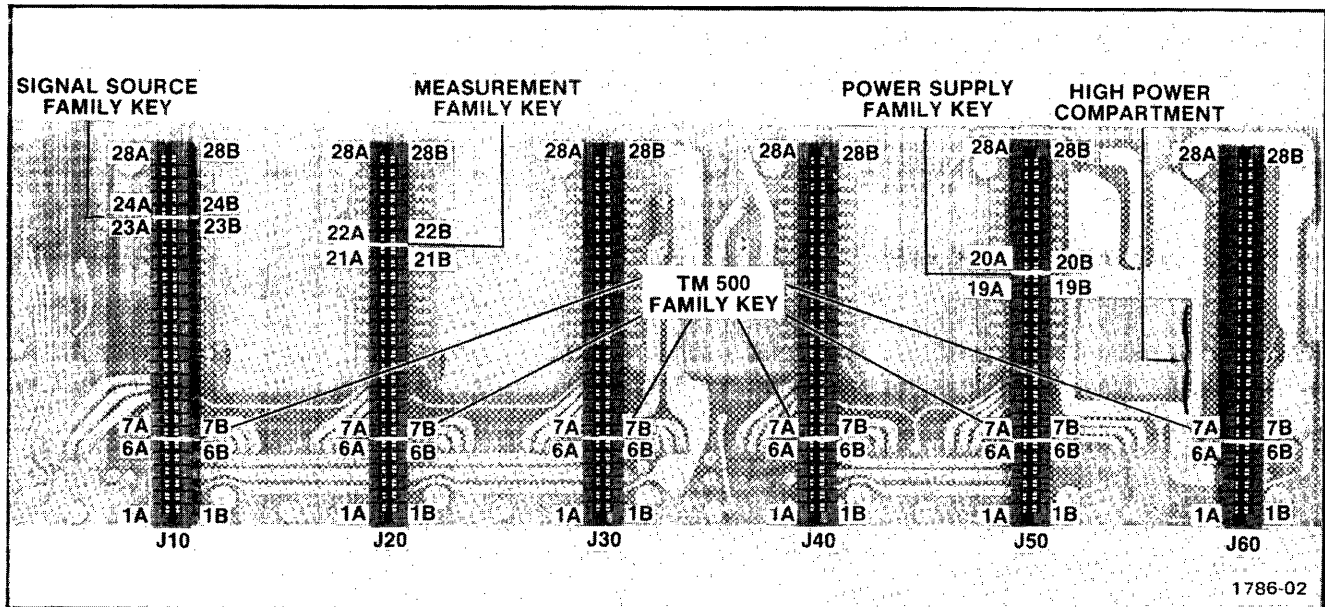

Fig. 2-1. Keying assignments for family functions. One of many possible sequence combinations.

## INSTALLATION AND PRE-TURN ON PROCEDURE

Check the rear panel markings. If the factory settings are compatible with the available line voltage and frequency, insert the desired plug-ins and use the bail to raise the front of the instrument. If a change is needed, refer a qualified service person to the procedure in the Maintenance section of this manual.

## RACKMOUNTING

The rackmount version of the TM 506 Power Module is designed for operation in a standard 19-inch wide rack that has Universal, EIA, RETMA, or Western Electric hole spacing. When properly mounted, this instrument will meet all electrical and environmental specifications given in Section 1.

### Mounting Method

This instrument will fit most 19-inch wide racks whose front and rear holes conform to Universal hole spacing; some drilling may be required on racks having EIA, RETMA, or Western Electric hole spacing. The slide-out tracks easily mount to the cabinet rack front and rear vertical mounting rails if the inside distance between the front and rear rails is within 10 9/16 inches to 24 3/8 inches. If the inside distance exceeds 24 3/8 inches, some means of support is required for the rear ends of the slide-out tracks. (For example, make extensions for the rear mounting brackets.)

### Rack Dimensions

**Height.** At least 5 1/4 inches of vertical space is required to mount this instrument in the rack. If other instruments are operated in the rack, an additional 1/4 inch is required, both above and below the TM 506, to allow space for proper circulation of cooling air.

**Width.** A standard 19-inch wide rack may be used. The dimension of opening between the front rails must be at least 17 5/8 inches for a cabinet in which the front lip of the stationary section is mounted behind an untapped front rail as shown in Fig. 2-2A. If the front rails are tapped, and the stationary section is mounted in front of the front rails as shown in Fig. 2-2B, the dimension between the front rails should be at least 17 3/4 inches. These dimensions allow room on each side of the instrument for the slide-out tracks to operate so the instrument can move freely in and out of the rack.

**Depth.** For proper circulation of cooling air, allow at least two inches clearance behind the rear of the instrument and any enclosure on the rack.

### Installing the Slide-Out Tracks

The slide-out tracks for the instrument consists of two assemblies, one for the left side of the instrument and one for the right side. Each assembly consists of three sections. A stationary section attaches to the front and rear rails of the rack; the frame section installed at the factory attaches to the instrument and the intermediate section fits between the other two sections to allow the instrument to fully extend out of the rack.

**Hardware.** The small hardware components included with the slide-out track assemblies are used to mount the tracks to most standard 19-inch vertical rack rails having this compatibility.

#### NOTE

1. Front and rear rail holes must be large enough to allow inserting a 10-32 screw through the rail mounting hole if the rails are untapped (see Fig. 2-2A).
2. Or, front and rear rail holes must be tapped to accept a 10-32 screw if Fig. 2-2B mounting method is used. Note in Fig. 2-2B right illustration that a No. 10 washer (not supplied) may be added to provide increased bearing surface for the slide-out track stationary section front flange.

Because of the above compatibility, there will be some small parts left over. The stationary and intermediate sections for both sides of the rack are shipped as a matched set and should not be separated. The matched sets of both sides including hardware are marked 351-0195-00 on the package. To identify the assemblies, note that the automatic latch and intermediate section stop is located near the top of the matched set.

**Mounting Procedure.** Use the following procedure to mount both sides. See Fig. 2-2 for installation details.

1. To mount the instrument directly above or below another instrument in a cabinet rack, select the appropriate holes in the front rack rails for the stationary sections, using Fig. 2-3 as a guide.
2. Mount the stationary slide-out track sections to the front rack rails using either of these methods:
  - (a) If the front flanges of the stationary sections are to be mounted behind the front rails (rails are counter-sunk or not tapped), mount the stationary sections as shown in Fig. 2-2A, right illustration.

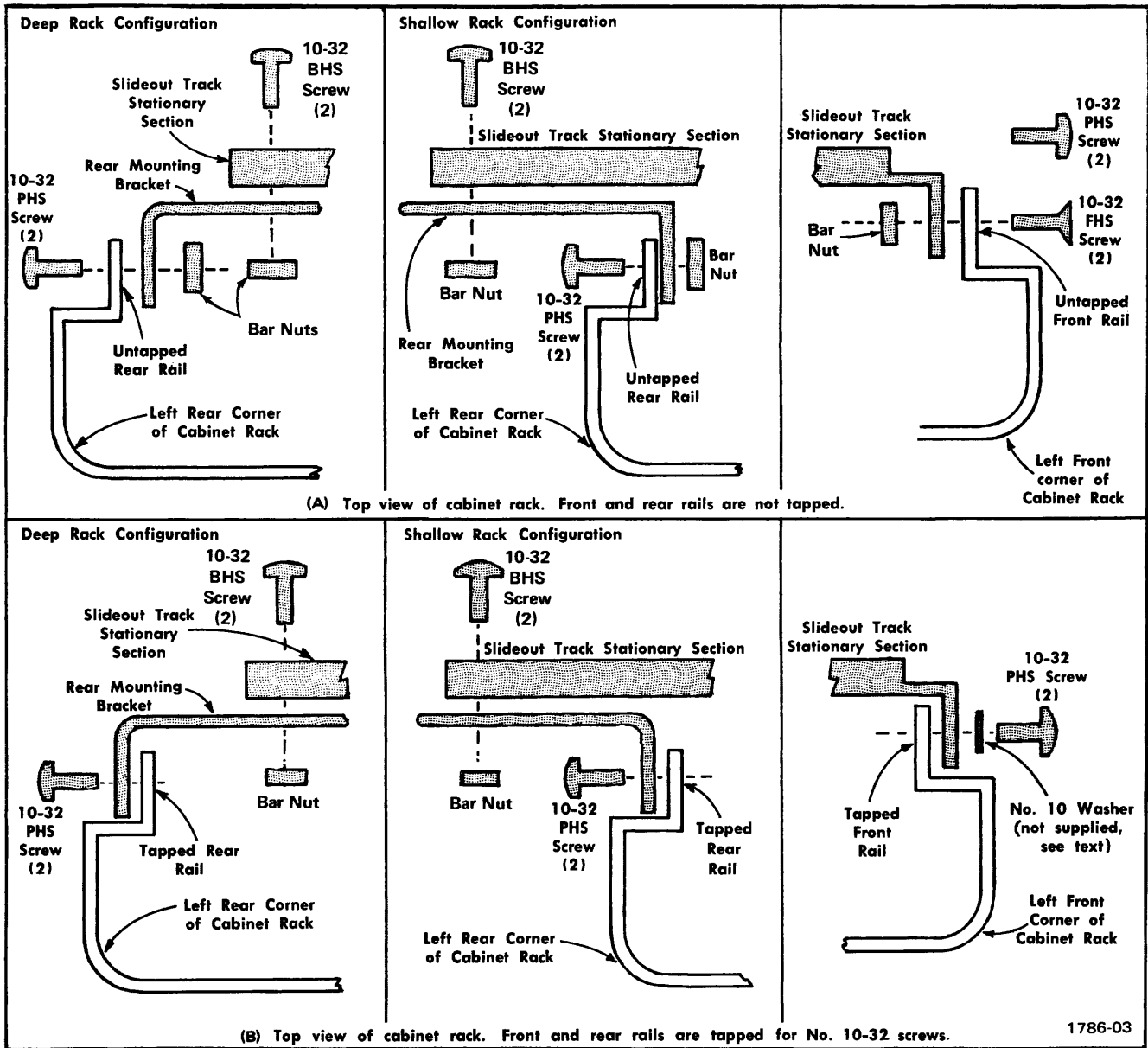

Fig. 2-2. Mounting the left stationary section (with its matched intermediate section, not shown in illustrations A and B) to the rack rails.

(b) If the front flanges of the stationary sections are to be mounted in front of the front rails (rails are tapped for 10-32 screws) mount the stationary sections as shown in Fig. 2-2B, right illustration. To provide increased bearing surface for the screw head to securely fasten the front flange to the rails, a flat washer (not supplied) may be added under the screw head.

However, if this mounting method is used, the front panel will not fit flush against the front rail because of the stationary section and washer thickness. If a flush fit is preferred, method 1(a) should be used.

3. Mount the stationary slide-out sections to the rear rack rails using either of these methods.

(a) If the rear rack rail holes are not tapped to accept 10-32 machine screws, mount the left stationary section with hardware provided as shown in the left or center illustration of Fig. 2-2A. Note that the rear mounting bracket can be installed either way so the slide-out tracks will fit a deep or shallow cabinet rack.

Use Fig. 2-2A as a guide for mounting the right stationary section. Make sure that the stationary sections are horizontally aligned so they are level and parallel with each other.

(b) If the rear rack rail holes are tapped to accept 10-32 machine screws, mount the left stationary section with hardware provided as shown in the left or center illustration of Fig. 2-2B. Note that the rear mounting bracket can be installed either way so the slide-out tracks will fit a deep or shallow cabinet track. Use Fig. 2-2B as a guide for mounting the right stationary section. Make sure the stationary sections are horizontally aligned so they are level and parallel with each other.

### TM 506 Installation And Adjustment

To insert the instrument into the rack, proceed as follows:

1. Pull the slide-out track intermediate sections out to the fully extended position.
2. Insert the instrument chassis sections into the intermediate sections.

3. Press the stop latches on the chassis sections and push the instrument toward the rack until the latches snap into their holes.

4. Again press the stop latches and push the instrument into the rack.

To adjust the slide-out tracks for smooth sliding action, loosen the screws used to join the stationary sections to the rails of the rack. Center the instrument, allowing the slide-out tracks to seek the proper width, then tighten the screws.

To secure the instrument front-panel to the rack, the rack must either have universal hole spacing, or a hole must be drilled and tapped for a 10-32 screw, see Fig. 2-3. Using the hardware (not furnished) indicated in Fig. 2-3, secure the TM 506 to the front rails of the rack.

### Slide-Out Track Maintenance

The slide-out tracks require no lubrication. The special dark gray finish on the sliding parts is a permanent lubrication.





# INSTRUCTIONS D'UTILISATION

## Installation

Les instructions complètes d'installation figurent à la fin de ce chapitre.

## Source d'alimentation

Le TM 506 est conçu pour fonctionner à partir d'une source d'alimentation dont le neutre se trouve au potentiel de la terre ou en est très peu différent, avec un conducteur de protection mis à la terre et séparé. Il n'a pas été prévu pour fonctionner entre deux phases d'un réseau multiphasé.

## Consommation

Avec 5 tiroirs installés dans le châssis d'alimentation, le TM 506 peut nécessiter jusqu'à 320 W de puissance dans la gamme supérieure de la tension réseau. La consommation effective est fonction des caractéristiques du tiroir et du mode d'utilisation sélectionnés.

**Compartiment haute puissance.** Certains tiroirs de la série TM 500 requièrent une puissance accrue afin de pouvoir fonctionner au maximum de leurs possibilités. Pour satisfaire à cette exigence, le TM 506 possède un compartiment haute puissance. Lorsque l'on regarde l'avant de l'appareil, ce compartiment se trouve à droite.

**Considérations de charge.** Afin d'employer au mieux la capacité de puissance du TM 506, il faut déterminer avec grand soin la configuration des tiroirs, les charges externes ainsi que les consommations respectives. Une utilisation optimale consiste :

1. A répartir des charges égales dans tous les compartiments.
2. A consommer le maximum de puissance dans les charges extérieures.
3. A utiliser l'ensemble à une température ambiante d'environ 25°C.

Le TM 506 alimente chaque tiroir par l'intermédiaire d'une paire de transistors (un NPN et un PNP) montés sur châssis servant de radiateur. Ces transistors, montage série, permettent d'abaisser les tensions d'alimentation nécessaires au tiroir utilisé sans dissiper de puissance dans les tiroirs eux-mêmes.

## Température de fonctionnement

Le TM 506 peut être utilisé à une température ambiante comprise entre 0°C et 50°C. Un disjoncteur thermique protège l'ensemble en déconnectant la source d'alimentation du

TM 506 lorsque la température interne dépasse un seuil de fonctionnement de sécurité. Ce dispositif rétablit automatiquement l'alimentation de l'appareil lorsque la température interne est redevenue normale.

Puisque le TM 506 peut être stocké à une température comprise entre -40°C et +75°C, il faut laisser au châssis le temps d'atteindre la température normale d'utilisation avant de mettre l'appareil sous tension.

## Tiroirs

Il n'est pas nécessaire d'utiliser tous les compartiments pour faire fonctionner le châssis d'alimentation. Les seuls modules nécessaires sont ceux requis pour réaliser une fonction.

### ATTENTION

*Couper l'alimentation du TM 506 avant l'insertion ou l'extraction de tout tiroir, des arcs électriques risquant de détériorer les circuits.*

## Installation du module

1. Vérifier que les détrompeurs en plastique, situés sur les connecteurs du TM 506 correspondent aux encoches du circuit imprimé du tiroir utilisé.
2. Aligner les rainures supérieures et inférieures du tiroir avec les guides du compartiment sélectionné. Insérer le tiroir et le pousser à fond pour que le circuit imprimé se place correctement dans le connecteur (pour extraire le tiroir, tirer sur la tirette de verrouillage située au coin inférieur gauche du panneau avant).

## Mise en service

Après avoir terminé les opérations de mise en service (informations détaillées à la fin de ce chapitre) et installé les tiroirs, tirer le commutateur PULL ON, situé sur le côté droit du TM 506. Certains tiroirs sont munis de commutateurs de mise en service indépendants, normalement dénommés OUTPUT. Ceux-ci transmettent les alimentations du châssis d'alimentation vers le tiroir sélectionné. Appuyer sur ces boutons pour mettre ces tiroirs en service.

## CONCEPTION D'UN SYSTEME

### Compatibilité

Mécaniquement, les tiroirs modulaires de la série TM 500 sont très similaires aux autres familles de produits Tektronix. Cependant, ils ne sont pas compatibles électriquement. Par

conséquent, l'interface du TM 506 est muni de détrompeurs situés sur les connecteurs correspondants, entre les broches 6 et 7. Cette conception empêche l'insertion de tout tiroir qui ne serait pas compatible. Se reporter à la figure 2-1. Un tiroir compatible doit posséder une encoche correspondante au détrompeur entre les broches 6 et 7 sur le connecteur de son circuit imprimé principal. L'association d'une encoche et de son détrompeur permet l'identification de la fonction et assure la compatibilité des tiroirs.

La tirette de sécurité de couleur blanche est un autre moyen d'identifier la compatibilité des tiroirs de la série TM 500.

### Conception de l'interface selon les besoins spécifiques du client

La modularité de ce système permet de réaliser une multitude de fonctions à l'aide des tiroirs. Des fonctions spécifiques sont regroupées par familles ou catégories, chacune de ces familles pouvant comprendre plusieurs tiroirs, par exemple, les familles d'alimentations, de générateurs de signaux, d'instruments de mesures, etc... Chaque tiroir modulaire, membre d'une famille réalisant la même fonction possède une seconde encoche assignée à cette famille et située sur le connecteur. L'utilisateur du TM 506 peut donc « programmer » un ou plusieurs compartiments afin que ceux-ci n'acceptent que les membres d'une même famille. Pour cela, il suffit d'installer un second détrompeur sur le connecteur d'interface en face de l'encoche correspondante. Un appareil TM 506 complet peut être personnalisé de cette manière, en permettant l'élaboration du système d'instructions pour des fonctions spécifiques. Pour se procurer des détrompeurs supplémentaires, passer commande la référence Tektronix 214-1593-02.

Des cavaliers câblés peuvent spécialiser l'interface. Des compartiments peuvent ainsi « se parler » en connectant des cavaliers du côté arrière de la carte d'interface par l'intermédiaire des broches d'interconnexion 14 à 28 (côtés A et B ensemble). Pour de plus amples informations, se reporter à la description de l'option 02. Se reporter également au manuel d'instructions concerné afin de connaître l'assignation de chaque broche I/O (entrée/sortie) placée sur l'interface arrière. Après avoir réalisé les interconnexions pour une utilisation spécialisée, il est recommandé d'installer les détrompeurs de telle sorte qu'ils garantissent la compatibilité du module avec le câblage effectué.

### Panneau arrière

Le panneau arrière est perforé afin de recevoir des prises BNC et un connecteur multi-broches. Les connecteurs et le câblage, montés en usine ou installés par l'utilisateur (se reporter à la description de l'option 02) donnent accès aux entrées/sorties externes par l'intermédiaire de l'interface. Cette caractéristique confère aux systèmes de mesures de la série modulaire TM 500 une grande souplesse d'emploi qu'il s'agisse de systèmes en coffret ou en baie.

**Option 02.** Cette option, installée en usine, consiste à adjoindre des connecteurs à broches carrées sur l'arrière de l'interface. Ils sont montés sur les emplacements des broches 14A et B à 28A et B. Cette souplesse d'utilisation de l'interface favorise la modification rapide et aisée du câblage pour une utilisation propre aux besoins du client. On utilise alors des câbles préparés et munis de prises femelles pour broches carrées et de pinces à longs ceochets. Ce système protège également le circuit imprimé des détériorations pouvant provenir des soudures et dessoudures répétées. Cette option comprend 6 connecteurs BNC et un connecteur à

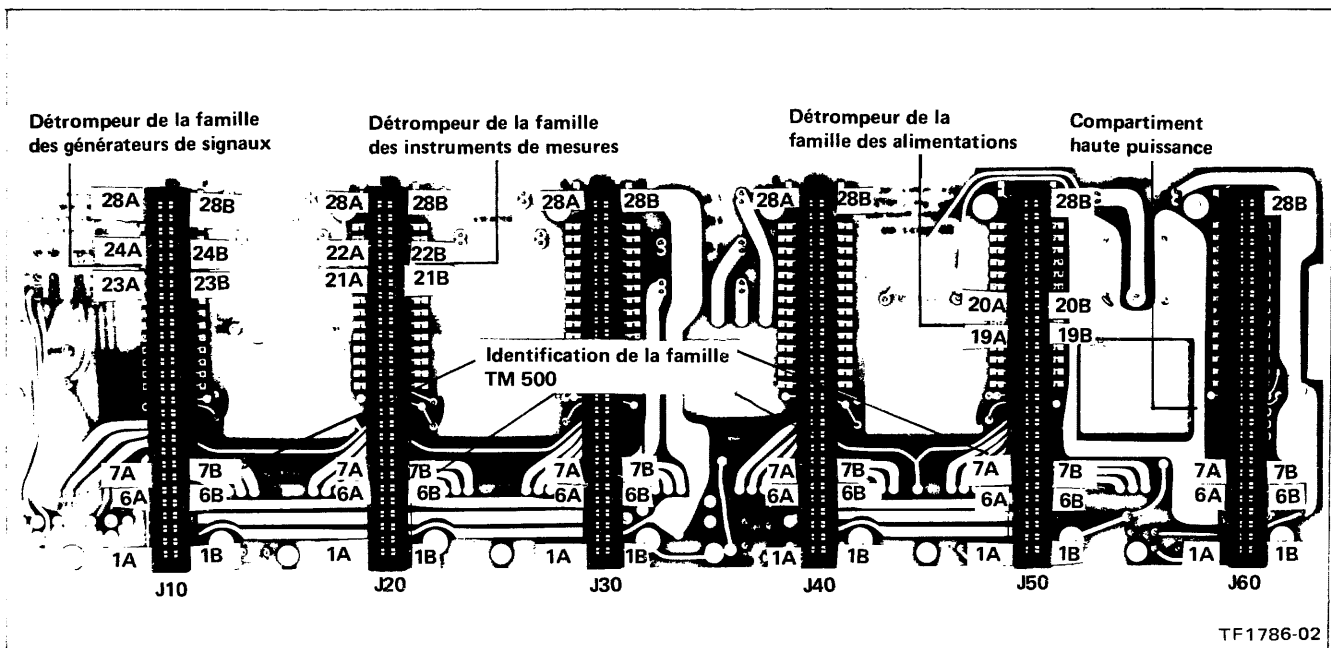

Fig. 2-1. Identifications des fonctions par familles. Un exemple des nombreuses combinaisons possibles.

50 broches sur le panneau arrière. Ces connecteurs ne sont pas précâblés afin que l'utilisateur puisse concevoir son système avec souplesse. Des détrompeurs font partis du kit global.

## INSTALLATION ET PROCEDURE DE MISE EN ROUTE

Vérifier les repères du panneau arrière. Si les montages effectués en usine sont compatibles avec la tension réseau et la fréquence disponibles, insérer les tiroirs souhaités et utiliser la barre d'appui pour incliner l'avant de l'appareil. Si une modification est nécessaire, faire appel à un personnel qualifié et se reporter à la méthode figurant au chapitre «Maintenance» du manuel en Anglais.

### MONTAGE EN BAIE

La version «Montage en baie» du châssis d'alimentation TM 506 est conçue pour utiliser l'appareil dans une baie standard de 48,26 cm. L'espacement des trous correspond aux normes universal, EIA, RETMA ou Western Electric. L'appareil, correctement monté, satisfait à toutes les caractéristiques électriques et d'environnement énumérées au chapitre 1.

#### Méthode de montage

Cet appareil s'adapte à la plupart des baies 19 pouces. L'espacement des trous arrières et frontaux est conforme au système UNIVERSAL. Il est nécessaire de modifier l'espacement des trous sur les baies EIA, RETMA ou WESTERN ELECTRIC. Les rails latéraux à glissières s'adaptent aisément sur les rails de montage verticaux à l'avant et à l'arrière de la baie si la distance interne entre les rails frontaux et arrières est comprise entre 26,82 cm et 61,91 cm. Si cette distance est supérieure à 61,91 cm, des pièces additionnelles sont nécessaires pour les extrémités arrières des rails à glissières (par exemple, certaines extensions pour les supports de montage arrière).

#### Dimensions requises de la baie

**Hauteur.** L'installation dans la baie requiert une hauteur minimale de 13,33 cm. Si l'on veut installer d'autres appareils dans la baie, il faut ménager un espace supplémentaire de 0,63 cm, au-dessus et au-dessous du TM 506 pour la libre circulation de l'air.

**Largeur.** Le TM 506 est conçu pour être monté dans une baie de 48,26 cm. La distance minimale d'ouverture entre les rails frontaux doit être de 44,76 cm, pour une baie dont le rebord avant de la partie fixe se monte derrière un rail frontal non taraudé (selon l'exemple de la figure 2-2A). Si

les rails frontaux sont taraudés et que la partie fixe se monte en face des rails frontaux, comme le montre la figure 2-2B, la dimension minimale entre les rails frontaux doit être de 45,08 cm, afin de laisser un espace suffisant de chaque côté pour ne pas entraver le jeu des glissières lors de l'insertion ou de l'extraction de l'appareil.

**Profondeur.** Ménager un espace d'au moins 5 cm derrière l'appareil pour permettre la libre circulation de l'air ventilé.

#### Installation des rails à glissière

Les rails à glissières du TM 506 sont constitués de deux ensembles, un par côté. Chaque assemblage est composé de trois parties : une «pièce» fixe qui se monte sur les rails frontaux et arrières de la baie, une «pièce» généralement montée en usine qui s'adapte à l'appareil et une partie intermédiaire qui se glisse entre les deux autres pièces pour permettre l'extension totale de l'appareil hors de la baie.

**Parties mécaniques.** Les petites pièces mécaniques jointes aux assemblages des rails à glissières sont destinés au montage de la plupart des rails verticaux 19 pouces compatibles.

#### NOTA

1. Les trous du rail frontal et du rail arrière doivent être suffisamment larges pour permettre le montage d'une vis 10-32 à travers le trou de montage du rail si les rails ne sont pas taraudés (se reporter à la figure 2-2A).

2. Sinon, les trous du rail frontal et du rail arrière doivent être taraudés pour accepter des vis 10-32 (méthode de montage, figure 2-2B). Noter qu'à droite de la figure 2-2B, une rondelle n° 10 (qui n'est pas fournie avec l'appareil) peut être ajoutée, fournissant ainsi une surface de portée accrue pour la partie frontale fixe du rail à glissière.

En raison de la compatibilité ci-dessus, certaines petites pièces seront mises à part. Les parties fixes et les glissières des deux côtés de l'appareil sont livrées assemblées et ne doivent pas être séparées. Le montage mécanique correspondant à chaque côté est référencé 351-0195-00. Pour identifier ces assemblages, noter que le verrou automatique et la partie intermédiaire d'arrêt sont à proximité du haut du montage apparié.

**Méthode de montage.** Se reporter à la figure 2-2 pour les détails d'installation.

1. Pour monter l'appareil directement au-dessus ou au-dessous d'un autre appareil dans une baie, il faut sélectionner les trous appropriés des rails frontaux de montage pour les parties fixes à l'aide de la figure 2-3.

2. Monter les parties fixes des rails à glissières sur les rails de montage frontaux en utilisant l'une de ces méthodes.

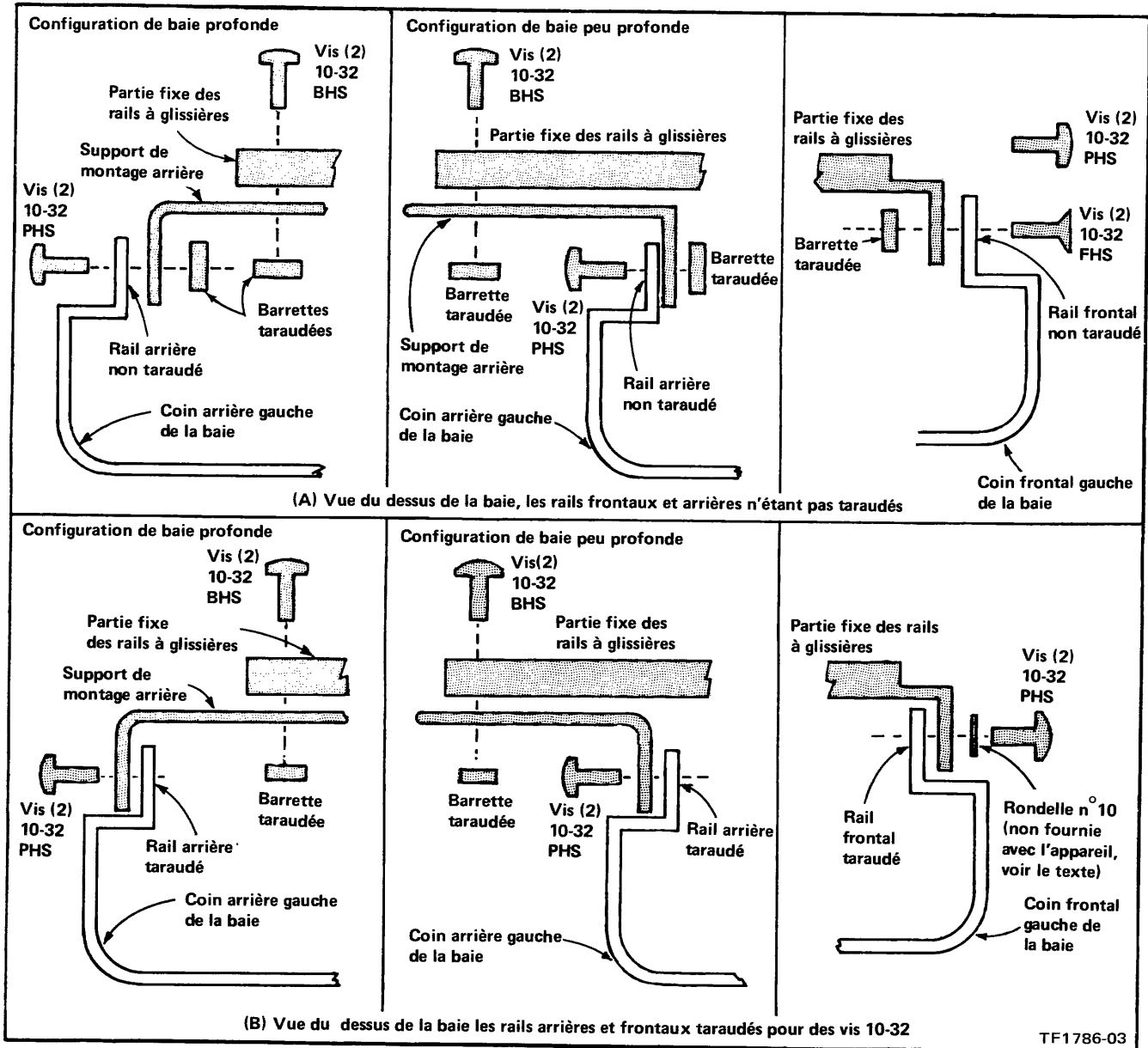

Fig. 2-2. Montage de la partie fixe gauche (avec sa partie intermédiaire correspondante, que l'on ne voit pas Fig. A et B) sur les rails conducteurs.

(a) Si les appareils avant des parties fixes doivent être montés derrière les rails frontaux (les rails ne sont pas taraudés), monter les parties fixes comme l'indique la figure 2-2A, illustration de droite.

(b) Si les supports avant des parties fixes doivent être montés devant les rails frontaux (les rails sont taraudés pour des vis de 10-32), monter les parties fixes comme l'indique la figure 2-2B, illustration de droite. Pour une portée accrue de la tête de la vis et pour fixer solidement le support avant aux rails, on peut ajouter une rondelle plate (qui n'est pas fournie) sous la tête de la vis.

Cependant, si on utilise cette méthode, le panneau avant ne sera pas dans l'alignement avec le rail frontal en raison de l'épaisseur de la partie fixe et de la rondelle. Si l'on

souhaite un véritable alignement, il faut utiliser la méthode 1 (a).

3. Monter les parties de glissière fixe sur les rails de montage arrière à l'aide de l'une de ces méthodes :

(a) Si les trous du rail arrière de la baie ne sont pas taraudés pour accepter des vis 10-32, monter la partie fixe gauche à l'aide des pièces mécaniques fournies, comme l'indique la figure 2-2A au centre ou à gauche. Noter que la profondeur de la baie n'a aucune importance pour l'installation du support arrière. Se servir de la figure 2-2A pour monter la partie fixe droite. S'assurer que les parties fixes sont alignées horizontalement afin qu'elles soient parallèles et au même niveau l'une par rapport à l'autre.

(b) Si les rails arrières de la baie sont taraudés pour accepter des vis 10-32, monter la partie fixe gauche avec les pièces mécaniques fournies, comme l'indique la figure 2-3B, au centre et à gauche. Noter que la profondeur de la baie n'a aucune importance pour l'installation du support arrière. Se servir de la figure 2-2B pour monter la partie fixe droite. S'assurer que les parties fixes sont alignées horizontalement afin qu'elles soient parallèles et au même niveau par rapport à l'autre.

### Installation et réglage du TM 506

Pour insérer l'appareil dans la baie, procéder comme suit :

1. Tirer les parties intermédiaires des rails à glissière jusqu'à complète extension.
2. Insérer le châssis de l'appareil dans les parties intermédiaires.
3. Appuyer sur les verrous d'arrêt et pousser l'appareil à l'intérieur de la baie jusqu'à ce que les verrous s'enclenchent.

4. Appuyer à nouveau sur les verrous d'arrêt et pousser l'appareil dans la baie.

Pour ajuster le glissement des rails, desserrer les vis utilisées pour assembler les parties fixes aux rails de l'appareil. Centrer l'appareil pour permettre aux rails à glissières de trouver la bonne largeur, puis resserrer les vis.

Pour que le panneau avant de l'appareil soit bien ajusté sur la baie, l'espacement des trous doit être standard. Sinon, un trou doit être percé et taraudé pour une vis 10-32, voir figure 2-3. A l'aide des pièces (non fournies) indiquées figure 2-3, fixer de manière sûre le TM 506 sur les rails frontaux de la baie.

### Maintenance des rails à glissières

Les rails à glissières ne nécessitent pas de graissage, le revêtement gris sombre sur les glissières étant auto lubrifiant.

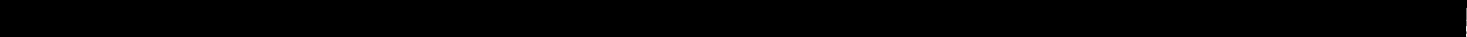
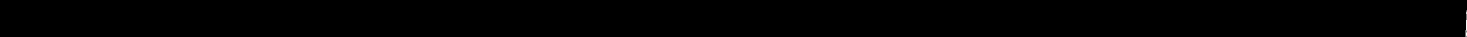
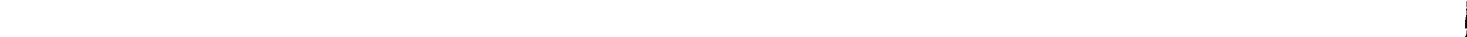
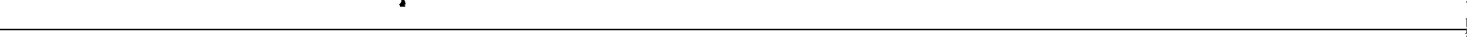
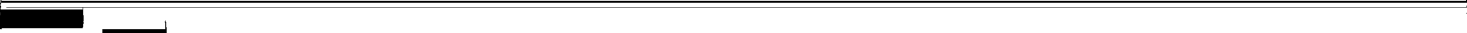
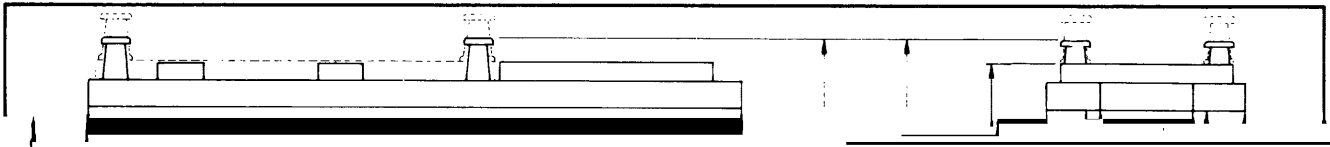

# BEDIENUNGSANLEITUNG

## Einbau

Die gesamten Einbauanweisungen finden Sie am Ende dieses Kapitels.

## Netzspannung

Die Versorgungseinheit TM 506 muß an ein Lichtnetz mit neutralem oder geerdetem separatem Nulleiter angeschlossen werden. Sie ist nicht für den Anschluß an Zwei- oder Mehrphasennetze geeignet.

## Leistungsaufnahme

Bestückt mit 6 Einschüben nimmt die Versorgungseinheit TM 506 bis zu 320 W an einem 220 V Netz auf. Die tatsächliche Leistungsaufnahme hängt von der Kombination der einzelnen Einschübe und deren momentanen Betriebsarten ab.

**Hochleistungs-Einschubfach.** Einige TM 500-Einschübe benötigen ein Hochleistungs-Einschubfach, um ihre maximalen Daten zu erreichen. Um diesen Anforderungen zu genügen hat die Versorgungseinheit TM 506 ein Hochleistungs-Einschubfach. Es handelt sich dabei um das rechte Schubfach, wenn man von vorne auf die Versorgungseinheit schaut.

**Belastungsmöglichkeiten.** Der optimale Leistungsverbrauch der Versorgungseinheit TM 506 kann durch Planung der Schubzusammensetzung, der externen Lasten und der resultierenden Verlustwärme bestimmt werden. Optimale Bedingungen werden erhalten durch:

1. Gleiche Belastung aller Schubkanäle.
2. Verbrauch von soviel Lasten wie möglich in den externen Lasten.
3. Betrieb des Systems in einer Umgebungstemperatur von etwa 25°C.

Jeder Schub hat Zugriff zu einem, auf einem Kühlblech montierten Leistungstransistorpaar (als Längstransistoren arbeitend). Diese Transistoren, je ein NPN- und PNP-Typ, ermöglichen den Schüben in Leistungsbereichen zu arbeiten, die nicht erreichbar wären, würde die Verlustleistung innerhalb der Schübe abfallen.

## Betriebstemperaturen

Die TM 506 kann in einem Umgebungstemperaturbereich von 0°C bis 50°C arbeiten. Die Geräte sind durch thermische Abschaltvorrichtungen, die bei hohen Temperaturen ansprechen, wirkungsvoll geschützt. Nach der Wiederherstellung der Betriebstemperatur schaltet sich die TM 506 automatisch wieder ein.

Die Lagerung der TM 506 kann in einem Temperaturbereich von -40°C bis +75°C erfolgen. Die Inbetriebnahme hat jedoch in den vorgeschriebenen Temperaturgrenzen zu erfolgen.

## Versorgungseinheit

Für die Inbetriebnahme der TM 506 Versorgungseinheit ist es nicht zwingend, alle Schubfächer zu bestücken, es sind nur die Schübe einzubauen, die für die Anwendung erforderlich sind.

**VORSICHT**

*Die Versorgungseinheit TM 506 sollte vor Einfügen oder Herausnahme eines Schubs ausgeschaltet werden, da Funkenbildung entstehen und die Schaltkreise beschädigen könnte.*

## Einschubeinbau

1. Überprüfen Sie, ob der Plastiksteg in der rückwärtigen Buchsenleiste der TM 506 Versorgungseinheit so positioniert ist, daß er mit der Aussparung in der Steckerleiste der Schübe übereinstimmt.

2. Setzen Sie den Schub in die obere und untere Führung der Versorgungseinheit und schieben Sie ihn bis er in der hintern Buchsenleiste einrastet. (Entfernen Sie den Schub durch Ziehen an der weißen Entriegelungsklinke in der linken unteren Ecke jedes Frontpanels.)

## Einschaltvorgang

Zum Einschalten ist der Netzschalter auf der Rückseite der TM 506 in die Position ON (Ein) zu drücken. Einige Schübe verfügen über einen Schalter, der nach dem Einschalten der TM 506 Versorgungseinheit zu betätigen ist.

# AUFBAU EINES MESSSYSTEMS

## Kompatibilität

Mechanisch sind die Einschübe anderen Tektronix-Produkten sehr ähnlich, jedoch elektrisch nicht kompatibel. Aus diesem Grund besitzt die TM 506 in den Buchsenleisten zwischen den Stiften 6 und 7 Sperrriegel, wodurch das Einsetzen eines falschen Einschubes verhindert wird.

Siehe Abb. 2-1. Ein kompatibler Einschub verfügt in seiner Steckerleiste zwischen den Stiften 6 und 7 über

eine Aussparung. Diese Kombination von Riegel und Aussparung ist die grundsätzliche Verschlüsselung zwischen Einschüben und Versorgungseinheiten.

Darüber hinaus sind die kompatiblen TM 500-Einschübe durch einen weißen Entriegelungshebel zum Herausnehmen gekennzeichnet.



Abb. 2-1. Verschlüsselungsangaben für die Familien-Funktionen. Eine von vielen möglichen Kombinationen.

## Anwenderbezogenes Interface

Durch die Modularität dieses Gerätesystems ergibt sich je nach Kombination eine vielseitige Funktionserfüllung. Die speziellen Funktionen sind in Familien bzw. Klassen zusammengefaßt, denen verschiedene Einschübe zugeordnet sind, z.B. Netzteile, Signalgeneratoren und Meßgeräte. Jeder Einschub verfügt daher je nach Familienzugehörigkeit über eine weitere Aussparung in seiner hinteren Steckeranschlußleiste, die ihn klassifiziert. Dem Anwender wird hierdurch ermöglicht, durch Einbau von weiteren Isolierstegen seine Versorgungseinheit so zu programmieren, daß die Einschubfächer nur Einschübe mit bestimmten Funktionen aufnehmen. Zusätzliche Isolierstege haben die Tektronix Bestell-Nr. 214-1593-02.

Zur weiteren Spezialisierung des Interface sind Drahtbrücken zu verwenden, die eine Kommunikation der ein-

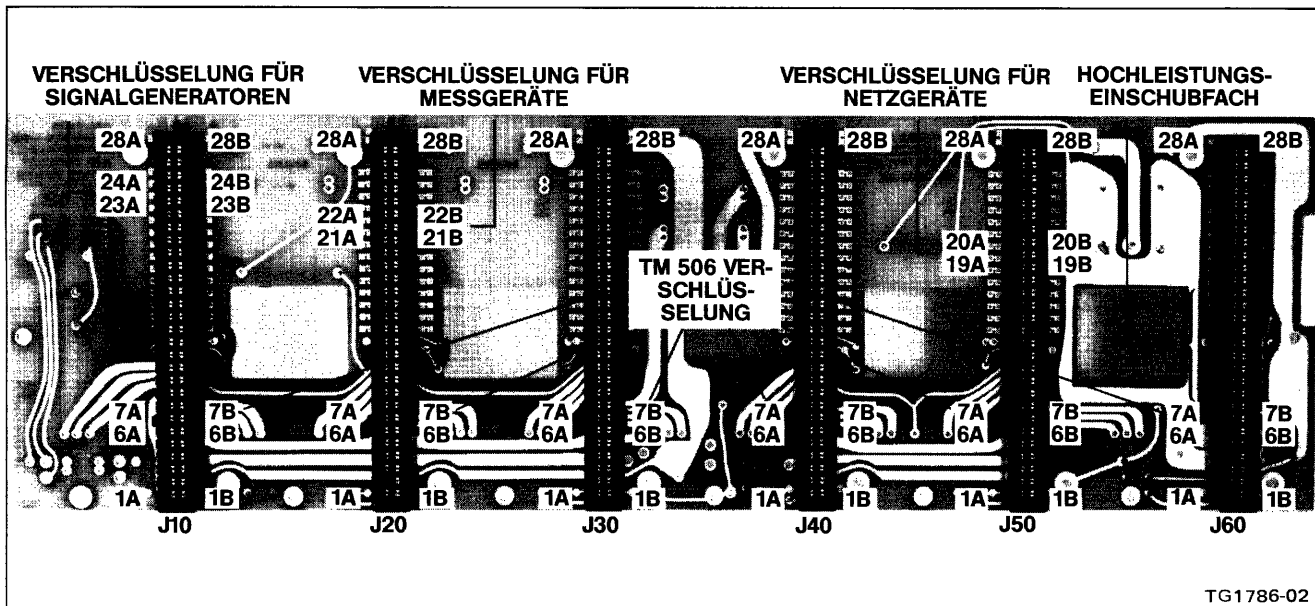
zelnen Einschubfächer untereinander gestatten. Hierzu sind die Stifte 14 bis 28 der A- und B-Seiten zu verwenden.

Eine Beschreibung hiervon ist unter Option 2 dieses Handbuches zu entnehmen. Darüber hinaus ist in jeder Einschubbeschreibung die Stiftbelegung der Steckerleiste zu beachten. Sind solche Zwischenverbindungen hergestellt, so ist es zwingend, auch Isolierstege einzubauen, die die Kompatibilität in der Verdrahtung sicherstellen.

## Rückseite

Auf der Rückseite der Versorgungseinheit TM 506 ist zum Einbau von BNC- und Mehrfachsteckern eine Montageplatte vorgesehen. Ein werkseitig oder vom Anwender



vorgenommener Einbau und Anschluß von Steckverbindungen (Beschreibung siehe unter Option 2) ermöglicht über das Interface, durch Zugriff von außen an das Interface, eine externe I/O-Steuerung. Durch diese Möglichkeiten wird aus der TM 500-Serie ein sehr flexibles modulares Instrumentensystem.

### Option 2

Mit dieser werkseitig installierten Option verfügt die Versorgungseinheit TM 506 über 25polige Steckverbindungen mit quadratischen Stiften, die mit den Stiften 14A und

B bis 28A und B der rückseitigen Steckverbindung der TM 506 verbunden sind. Hierdurch wird das Interface flexibel, da mit speziellen Verbindungsschnüren eine anwenderbezogene Verdrahtung schnell hergestellt werden kann, ohne daß auf der Platine nachträgliche Lötarbeiten durchgeführt werden müssen.

Darüberhinaus beinhaltet die Option noch BNC- und einen 50-poligen Stecker auf der Geräte-Rückseite. Diese Stecker sind nicht verdrahtet, um dem Anwender individuelle Möglichkeiten zu bieten. Ein mitgelieferter Kit verfügt über Stecker, Koaxialkabel und Isolierstege.

## EINBAU UND ANLEITUNG VOR DER INBETRIEBNAHME

Beachten Sie die Angaben auf der Rückseite. Stimmt die werkseitig erfolgte Einstellung der Betriebsspannung und Frequenz mit der vorhandenen überein, setzen Sie

den Stecker ein. Ist eine Änderung nötig, sollte sich ein qualifizierter Techniker auf die entsprechende Anleitung in diesem Manual beziehen.

## GESTELLEINBAU

Die Gestelleinbauversion der Versorgungseinheit TM 506 dient zum Einbau in Standard 19-Zoll Gestelle mit Universal-, EIA-, RETMA- oder Western-Electric Lochabstand. Bei ordnungsgemäßem Einbau erfüllt das Gerät die in Kapitel 1 aufgeführten Spezifikationen.

### Einbaumethode

Die Versorgungseinheit TM 506 paßt in die meisten 19-Zoll Gestelle, deren Front- und rückseitigen Löcher mit dem Universallochabstand übereinstimmen. Bei Gestellen mit EIA, RETMA oder Western Electric Lochabstand sind einige Bohrungen erforderlich. Die Gleitschienen sind leicht an den vertikalen Front- und Rückseitenbefestigungsschienen des Gestells zu montieren, wenn der Abstand der front- und rückseitigen Schienen im Bereich von 26,8 cm bis 62 cm liegt. Bei größerem inneren Abstand als 62 cm, ist eine Stütze für die hinteren Enden der Gleitschienen erforderlich (für die hinteren Montageklammern sind z.B. Verlängerungen anzufertigen).

### Gestellmaße

**Höhen.** Zum Einbau des TM 506 in ein 19-Zoll Gestell ist eine Höhe von mindestens 13,3 cm erforderlich. Sind noch weitere Geräte eingebaut, ist ein zusätzlicher Abstand, ober- und unterhalb des TM 506, von 0,6 cm einzuhalten, um eine ausreichende Belüftung zu gewährleisten.

**Breite.** Es kann ein Standard-19 Zoll Gestell verwendet werden. Der Abstand zwischen den Frontschienen muß mindestens 44,7 cm betragen, bei einem Gehäuse in dem der Frontschenkel des stationären Teils hinter einer, wie in Bild 2-2A dargestellten, mit Gewinde versehenen Frontschiene befestigt ist. Bei Frontschienen mit Gewinde, die vorn auf der Frontscheibe montiert sind – wie in Bild 2-2B dargestellt – ist ein Mindestabstand von 45 cm erforderlich. Die Maße schaffen auf jeder Seite genügend Spielraum für die Gleitschienen zum Ein- und Ausschleiben des Gerätes.

**Tiefe.** Um eine ausreichende Belüftung des Gerätes sicherzustellen, ist ein hinterer Mindestabstand von 5 cm zwischen Gerät und Gestellwand einzuhalten.

### Einbau der Gleitschienen

Die Gleitschienen des Gerätes bestehen aus 2 Einheiten, einer linken und einer rechten. Jede Einheit besteht aus drei Teilen: einem stationären Teil, der an den vorderen und hinteren Schienen des Gestells angebracht ist, dem Rahmenteil, das an die werkseitig angebrachten Vorrichtungen installiert wird und dem Mittelteil, das an die anderen beiden Teile angebracht wird, um ein völliges Herausziehen des Gerätes aus dem Gestell zu gestatten.

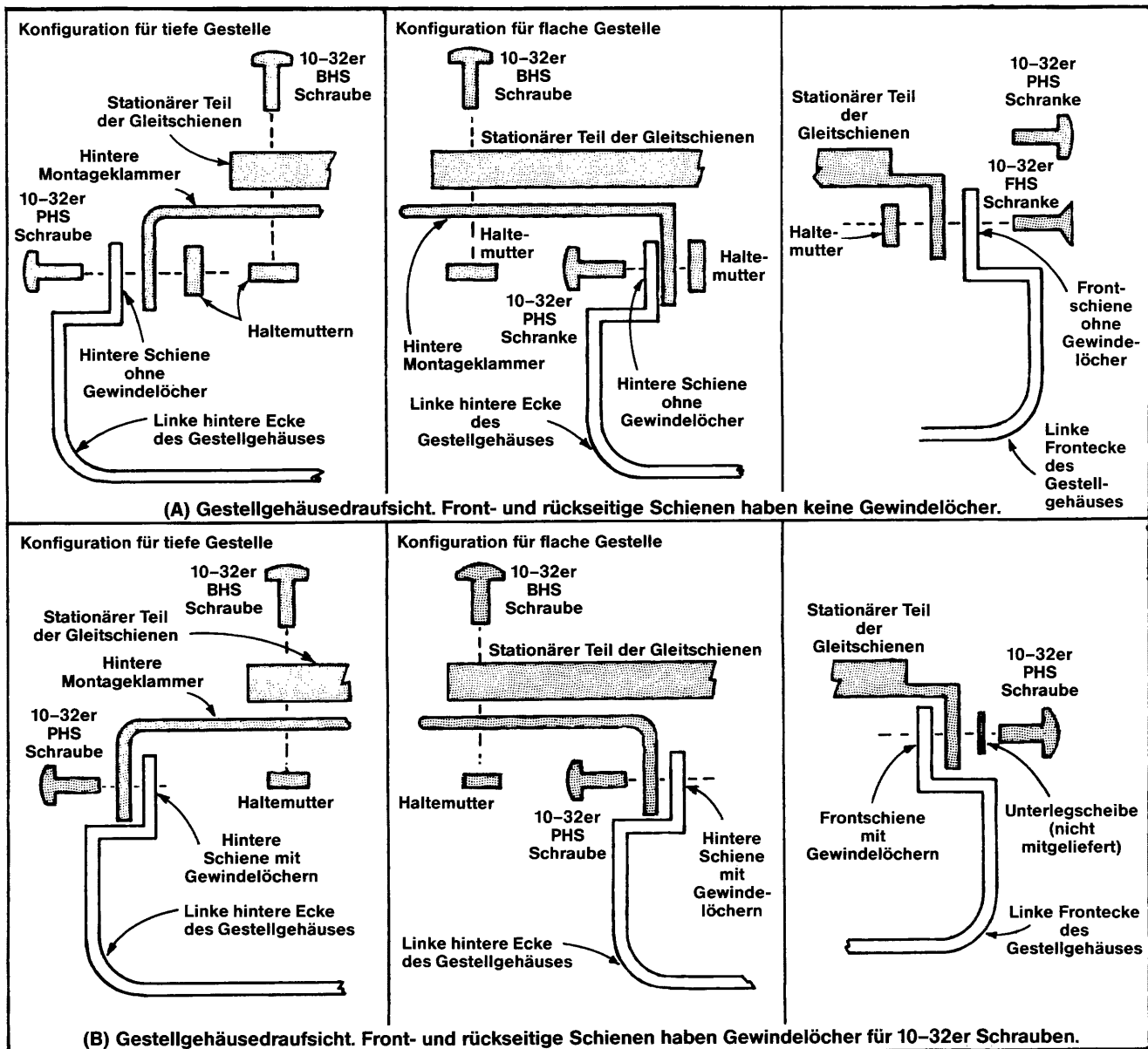

TG1786-03

Abb. 2-2. Einbau des linken stationären Teils an die Gestellschienen (mit den dazu passenden Zwischenteilen, die nicht in Bild A und B dargestellt sind).

**Einbauteile.** Die Einbauteile, die den Gleitschienen beigefügt sind, dienen zur Montage der Schienen in 19-Zoll Gestelle mit folgenden Bedingungen:

**BEACHT**

1. Die Löcher der vorderen und hinteren Schienen müssen groß genug sein, um 10-32er Schrauben aufzunehmen, wenn die Schienen - wie in Bild 2-2A dargestellt - nicht mit Gewinde versehen sind.

2. Bei der Montageart wie in Bild 2-2B ersichtlich, müssen die vorderen und hinteren Schienenlöcher mit einem Gewinde für 10-32er Schrauben versehen werden. Die rechte Abbildung zeigt die Verwendung einer 10er-Unterlegscheibe, um eine größere Auflagefläche am stationären Teil des Gleitschienen-Vorderflansches zu gewährleisten.

Wegen der verschiedenen Montagearten bleiben einige der Einbauteile übrig. Die Stationärteile und Mittelteile für beide Seiten des Gestells werden als zueinander passendes Set mitgeliefert, sie sollten nicht getrennt werden.

Die zueinander passenden Sets für beide Seiten mit Einbauteilen sind mit der Bestell-Nr. 351-0195-00 bezeichnet.

**Einbauvorgang.** Folgender Vorgang ist beim Einbau unter Beachtung von Abb. 2-2 einzuhalten:

1. Zum Einbau des Gerätes über oder unter einem anderen Gerät im Gestell, sind die entsprechenden Löcher auf den Frontschienen des Gestells zur Befestigung der stationären Teile zu verwenden (siehe Abb. 2-3)

2. Zur Befestigung der stationären Teile an den Frontschienen ist eine der nachstehend beschriebenen Methoden anzuwenden:

(a) Sind die vorderen Flansche des stationären Teils hinter den Schienen des Gestells anzubringen, so ist wie in Abb. 2-2A rechts, vorzugehen (bei nicht mit Gewinde versehenen Schienen).

(b) Sind die vorderen Flansche des stationären Teils vor den Frontschienen des Gestells anzubringen, so ist wie in Abb. 2-2B rechts dargestellt, vorzugehen (die Schienen sind mit Gewinde versehen). Um eine vergrößerte Auflagefläche für den Schraubenkopf zu erhalten, um den vorderen Flansch sicherer an den Schienen zu befestigen, ist eine flache Unterlegscheibe (nicht mitgeliefert) einzubauen.

Bei Anwendung von Methode (b), ist die Frontplatte nicht planeben mit der vorderen Schiene wegen des stationären Teils und der Unterlegscheibendicke. Ist eine planebene Montage erwünscht, muß Methode (a) angewendet werden.

3. Die stationären Gleitschienteile werden nach einer der beiden Methoden an den hinteren Gestellschienen angebracht.

(a) Sind bei den hinteren Schienenlöchern keine Gewinde für die 10-32er Schrauben vorhanden, ist der linke stationäre Teil mit den vorhandenen Montagekleinteilen anzubringen, wie in Abb. 2-2A links oder rechts dargestellt ist. Es ist zu beachten, daß die hintere Montageklammer unterschiedlich montiert werden kann, so daß die Gleitschienen in ein tiefes und auch in ein flaches Gehäusegestell passen.

Bei der Montage der rechten stationären Teile ist nach Abb. 2-2A vorzugehen. Es ist dabei auf horizontale Ausrichtung der Teile zu achten, so daß sie eben und parallel zueinander sind.

(b) Bei mit Gewinde versehenen Gestellschienenlöchern ist der linke stationäre Teil wie in Abb. 2-2B

(links oder Mitte) dargestellt, mit den vorhandenen Montagekleinteilen anzubringen. Es ist zu beachten, daß die hintere Montageklammer unterschiedlich montiert werden kann, so daß die Gleitschienen in ein tiefes und auch flaches Gehäusegestell passen. Zur Montage des rechten stationären Teils ist nach Abb. 2-2B vorzugehen. Es ist dabei auf horizontale Ausrichtung der Teile zu achten, so daß sie eben und parallel zueinander sind.

### Einbau und Justage des TM 506

Zum Einsetzen des Instrumentes in das Gestell ist folgendermaßen vorzugehen:

1. Ziehen Sie die mittleren Teile der Gleitschienen in die voll ausgefahrene Position.

2. Setzen Sie die Geräte-Chassis-Teile in die mittleren Teile ein.

3. Drücken Sie die Halteklippen auf die Chassisteile und schieben Sie das Gerät in Richtung des Gestells, bis die Klippen in ihre Löcher einrasten.

4. Drücken Sie noch einmal die Halteklippen und schieben Sie das Geräte in das Gestell hinein.

Zum Justieren der Gleitschienen für ein reibungsloses Gleiten, sind die Schrauben, die die stationären Teile an den Gestellschienen halten, zu lösen. Zentrieren Sie das Gerät indem Sie den Gleitschienen den entsprechenden Spielraum geben, dann ziehen Sie die Schrauben wieder an.

Zur Sicherung der Gerätefront am Gestell muß das Gestell entweder über universelle Löcher verfügen, oder es muß ein Loch gebohrt und mit 10-32er Gewinde versehen werden.

(Siehe Abb. 2-3) Zur Sicherung des TM 506 sind Kleinteile wie in Abb. 2-3 dargestellt (nicht mitgeliefert) zu verwenden.

### Wartung der Gleitschienen

Die Gleitschienen erfordern keine Schmierung. Die spezielle dunkelgraue Oberfläche der gleitenden Teile ist eine Dauerschmierung.



# 取 扱 説 明

## 取付け

取付け手順に関しては本章の最後の部分に述べられています。

## 電源

TM506型はアース電位の中性点を持った電源で使用するように設計されています。多相システムの2相または単相3線システムの2線で動作させることはできません。

## 消費電力

6台のプラグインが組み込まれた場合、TM506型は高い方の動作電圧で最高320Wの電力を必要とします。実際の消費電力はプラグインの組み合わせや動作状態によって変わります。

**高電力プラグイン・ホール** TM500シリーズのプラグインには、十分な機能を発揮するには高電力を必要とするものもあります。この要求に答えるため、TM506型には高電力プラグイン・ホールが備わっています。機器のフロントパネルに向かって一番右手のプラグイン・ホールが高電力供給用となっています。

**負荷について** 6つのプラグインを取付けた状態で、高電源電圧レンジに設定した場合に320Wまでの電力を必要とします。実際の消費電力はプラグインの組合せによって異なります。

電力はプラグインの機能的な組合せ、外部負荷、各々のプラグインの消費電力に注意して効率よくご使用下さい。最適の状態とは、

- (1) 向かって左側の5つのプラグイン・ホールがすべて同じ負荷で、高電力プラグイン・ホールでは負荷が最大であること。
- (2) 電力はできる限り外部負荷で消費すること。
- (3) 約25℃の周囲温度で使用すること。

TM506型は、各プラグインに対してシャーシで放熱されるNPN、PNPの各1個ずつのシリーズ・トランジスタによって電力を供給しています。

## 動作温度

TM506型は0～50℃の周囲温度で動作することができます。内部温度が安全動作温度以上に上がった場合には、サ

ーマル・カットアウト装置により自動的に電源が切断し、TM506型を保護します。この装置は内部温度が安全動作温度に復帰すれば再び電源を接続します。

TM506型の格納温度は-40℃～+75℃までですが、機器のシャーシが動作温度範囲内に戻ってから電源を投入して下さい。

## プラグイン

本体を動作させるのにすべてのプラグイン・ホールにプラグインを組み込む必要はありません。必要なプラグインのみ組み込んで下さい。

### 注 意

本体の電源スイッチを必ず切ってからプラグインを抜き差しして下さい。電源を入れたままプラグインを抜き差ししますと、プラグインの回路を破損する恐れがあります。

## プラグインの取付け

1. TM506型のコネクタ内にはいつているプラスチックの位置決めスペーサとプラグインのエッジ・コネクタのカット部分が一致していることを確認します。
2. TM506型のプラグイン・ホールの上下のガイドに沿ってプラグインを差し込み、さらにコネクタにプラグインのエッジ・コネクタがしっかりと固定されるまで押して下さい。プラグインを取りはずす場合には、左下隅にあるつまみをひっぱりそのまま引き抜きます。
3. TM506型の右側のPULL ON POWERボタンを引き出します。プラグインの中には独立した電源スイッチを持っているものもあり、通常OUTPUTと前面パネルに書かれています。プラグインを動作させるにはこのボタンを押します。

## 電源投入の手順

TM506型の後部パネルのPOWERスイッチをONの位置にします。プラグインの中には独立した電源スイッチを持っているものもあり通常OUTPUTと書かれています。プラグインを動作させるにはこのボタンを押します。これによってプラグインへの電源供給をコントロールすることができます。プラグインを作動させるには、本体の電源を入れてから、このスイッチを入れます。

## システム構成

### 互換性

当社のプラグインは外観上、他のシリーズ（7000、5000シリーズ）のプラグインと類似しています。しかし電気的には互換性がありません。他のシリーズのプラグインと組み合わせができないよう、**TM506型**のインターフェイス・コネクタのピン6と7に位置決めスペーサがはいつています。（2-1図参照）**TM500**シリーズのプラグインはメインのプリント基板上のピン6と7の部分がカットされてい

ます。このスペーサとカット部分が一貫していることを確認します。

**TM500**シリーズのプラグインの正面左下隅のレリーズ・ラッチの色は白ですので、他のシリーズのプラグインと簡単に識別できます。

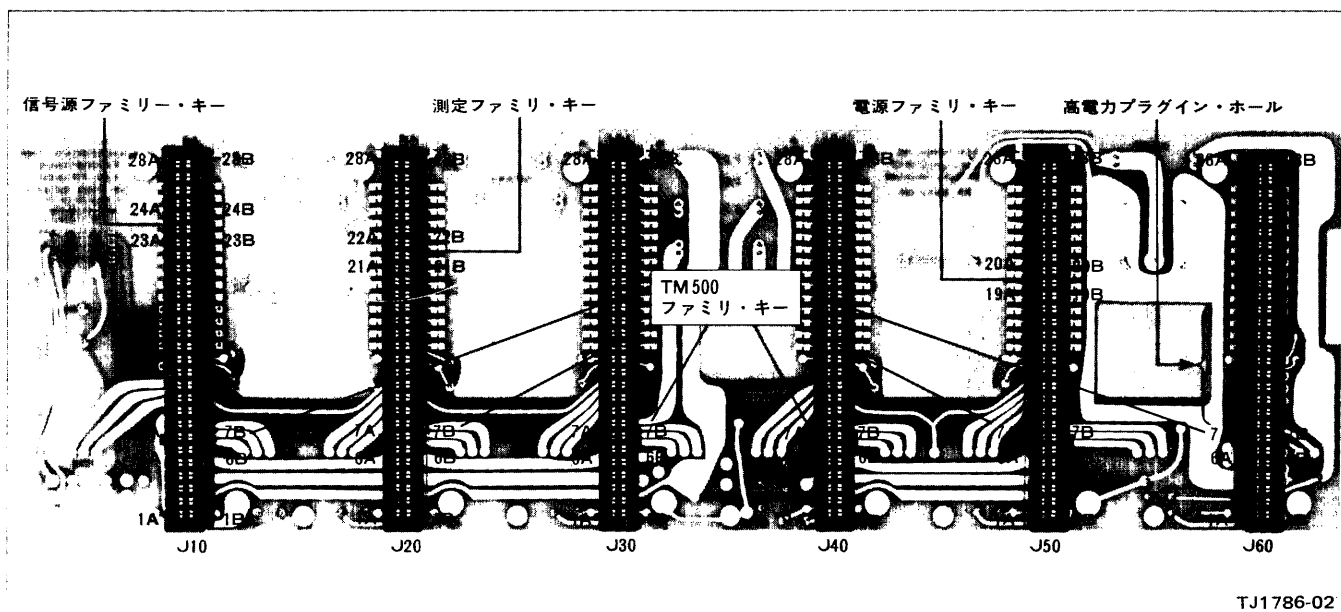

2-1図 機能によるキー割当。

### インターフェイス

**TM500**シリーズはプラグイン方式になっていますので多くの異なった機能を持たせることができます。また**TM500**シリーズを信号源、電源、測定器などいくつかの群にわけることができ、それら同種のプラグインに特定のプラグイン・ホールを割り当てるため、別に位置決めスペーサを挿入することもできます。この位置決めスペーサの追加によって、同種のプラグイン群のみ使用可能なプラグイン・ホールをプログラムすることができます。この方法で**TM506**型のすべてのプラグイン・ホールに特定の機能を持たせることができます。位置決めスペーサの部品番号は、214-1593-02です。

さらにジャンパ線を使うと内部でインターフェイスすることができます。内部コネクタのA面とB面のピン14~28（A・B両側とも）を使って、インターフェイス・ボードの後側をジャンパ線で接続することによりプラグインの信号を内部でやりとりすることができます。本マニュアルの**オプション02型**の説明の項をご参照下さい。後部インターフェイスの各ピンのI/Oの割り当てについては各プラグインの取扱説明書をお読み下さい。一旦特殊目的用にジャンパ線を接続したら内部インターフェイス・コネクタに位置決めスペーサを取付けて、ジャンパ線の配線に合わせたプラグインの適合性を保持するようにします。

## 後部パネル

後部補助パネルはBNCおよびマルチピン・コネクタを取付けるパンチ穴をあけることができます。オプションで最初から穴のあいたものもあります。穴があいていると後から取付けられたコネクタや配線で、外部I/O信号をインターフェイス・基板に接続するのに便利です。(オプション02型) この特長によりTM500シリーズ総合テストシステムをベンチ型またはラックマウント型いずれの場合にも非常に汎用性の高いシステムにしています。

オプション02型を指定しますと、インターフェイス・コ

ネクタの後側の14A～28Aおよび14B～28Bのすべてのピンの位置に25ミルの四角いピンが立てられます。これにより付属の角ピン・コネクタ付きワイヤをラジオ・ベンチまたはピンセットを使って簡単に素早く配線したり、変更したりすることができるのでインターフェイスが容易になります。またジャンパ線のハンダ付けの繰返しによるプリント基板の損傷を防ぐことができます。オプション02型ではさらに後部パネルにBNCコネクタ3個および50ピンコネクタ1個が取付けられます。これらのコネクタは配線されていませんので、システム設計者が任意に、用途に合わせて配線することができます。ジャンパ線、同軸ケーブル、位置決めスペーサがオプション02型には付属しています。

# 取付けおよび電源投入の手順

後部パネルのマークをチェックして下さい。電源電圧および周波数が、工場出荷時の設定に適合しているならば、プラグインを取付け、底部金具で機器前面を持ち上げて下

さい。設定をかえる必要がある場合には、当社フィールド・エンジニアにおたずね下さい。

## ラックへの取付け

TM506型電源モジュールのラックマウント・タイプは、ユニバーサル、EIA、RETMA、ウエスタン・エレクトリック規格の取付穴間隔を持つ標準の19インチ(48.3cm)幅ラックに取付けて使用するよう設計されています。適正に取付けた場合、本機器は第1章に述べた電気特性と耐環境性とをすべて満足します。

### 取付方法

TM506型は、前面および後部の取付穴がユニバーサル規格の取付穴間隔を満足する大部分の19インチ(48.3cm)幅ラックに適合します。EIA、RETMAまたはウエスタン・エレクトリック規格のラックについてはドリルによる多少の手直しが必要です。前面レールと後部レールとの間の内側寸法が26.8cm(10 $\frac{5}{16}$ インチ)と61.9cm(24 $\frac{3}{8}$ インチ)との間であれば、スライドアウト・トラックはそのままキャビネットラックの前面と後部の垂直マウンティング・レールに取付けられます。上記内側寸法が61.9cm(24 $\frac{3}{8}$ インチ)を超える場合には、スライドアウト・トラックの後端を何らかの方法で支える必要があります。(たとえば、後部マウンティング・ブラケットを延長します。)

### ラック寸法

高さ—TM506型をラックに取付けるには、13.3cm(5 $\frac{1}{4}$ インチ)以上の垂直スペースが必要です。同じラックに他の機

器を取付ける場合には、TM506型の上下に0.64cm( $\frac{1}{4}$ インチ)の余裕をとって、冷却用空気が流るようにする必要があります。

幅—標準の19インチ幅ラックが使用できます。前面レールとの間の開口部の寸法は、2-2(A)図に示すようにスライドアウト・トラック固定部の前面リップを、雌ねじの切っていない前面レールの後に取付けるようなキャビネットの場合、44.8cm(17 $\frac{5}{8}$ インチ)以上が必要です。前面レールに雌ねじが切つてある場合、およびスライドアウト・トラック固定部を2-2(B)図に示すように前面レールの前に取付ける場合には、前面レールの間隔は45.1cm(17 $\frac{3}{4}$ インチ)以上でなければなりません。これらの寸法が確保されれば、機器の両側にスライドアウト・トラックを動かすための隙間が保たれ、機器を自由に出し入れできます。

奥行—冷却用空気が流るようにするためには、機器の後面とラック後面カバーとの間に5cm(2インチ)以上の隙間が必要です。

### スライドアウト・トラックの取付

TM506型用のスライドアウト・トラックは、左側および右側用の2つのアセンブリから成っています。各アセンブリは3つの部分から構成されています。固定部はラックの前面および後部レールに取付けられます。フレームの部分

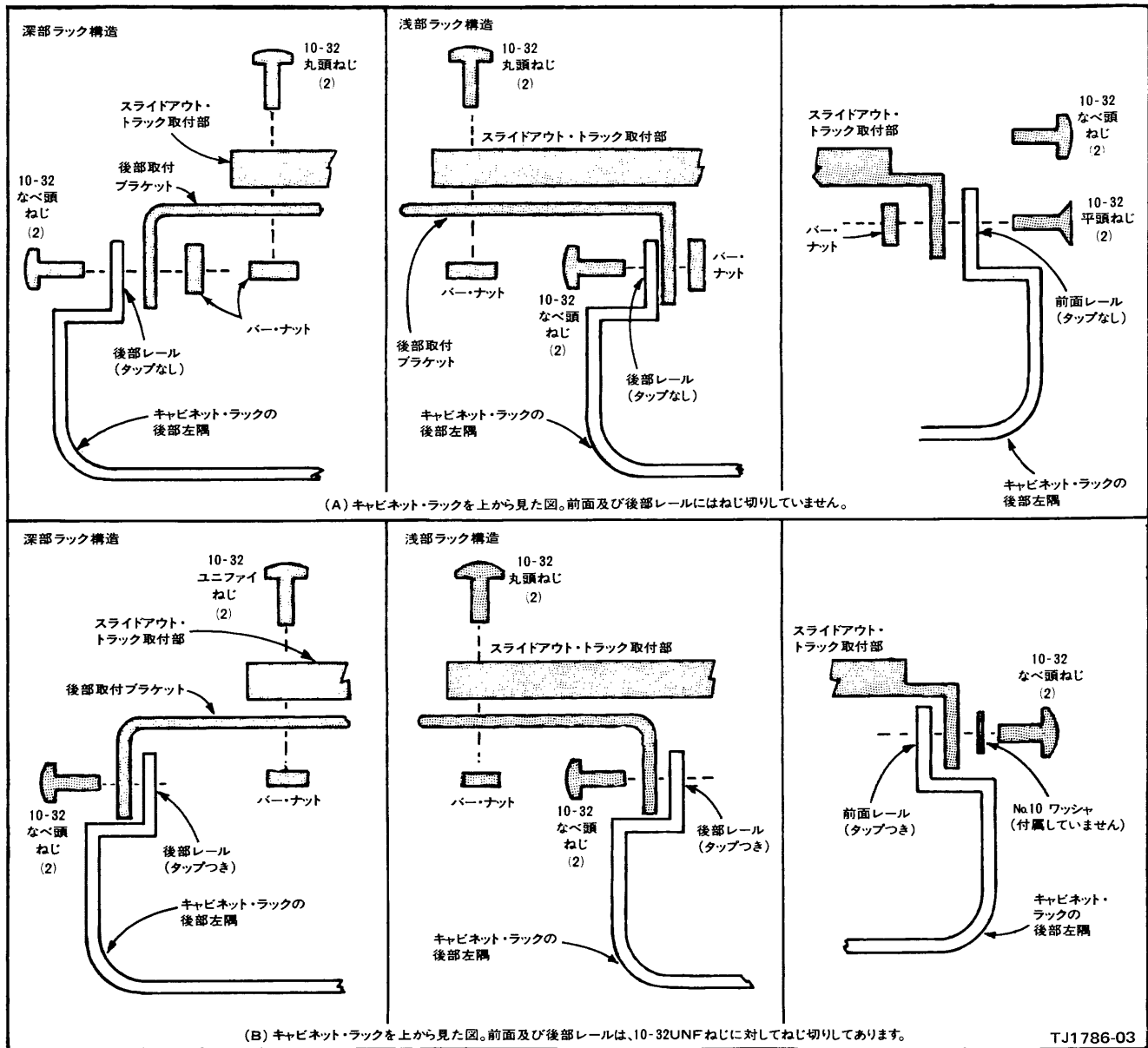

2-2 図 左側取付部(中間部に合わせてありますが、図中には示されていません。)のラック・レールへの取り付け。

は工場で機器に取付けられます。中間部はフレームと固定部の間に収まり、機器を十分にラックから引き出せるようになっています。

**取付金具**—スライドアウト・トラック・アセンブリに付属している小さな金具は、トラックを適切な19インチ垂直ラック・レールに取付けるのに用いられます。

**注**

1. レールに雌ねじが切られていない場合、前面および後部レールの穴は、レール取付穴を通して10-32UNFねじを挿入できる大きさでなければなりません。(2-2 A図参照)

2. 2-2 B図の取付法を利用する場合には、前面および後部レールの穴には10-32UNFねじ用の雌ねじを切る必要があります。2-2 B図の右図においてスライドアウト・トラック固定部の前面フランジの支持面を増やすためには、No.10ワッシャ(付属していません)を使用します。

なお、一部の小部品は使用しない場合もあります。ラック両側の固定部と中間部とは組合せセットとして出荷されますから、分離しないで下さい。取付金具も含めた両側の組合せセットのパッケージには部品番号 351-0195-00を記してあります。アセンブリを識別するために、オートマ



チック・ラッチと中間部ストップとが組合せセットの上部近くにおかれてあります。

**取付手順**—両側の組合せセットを取付ける際には、下記の手順に従って下さい。詳細は**2-2図**をご参照下さい。

1. キャビネット・ラック内で別の機器の直上または直下に機器を取付ける際には、**2-3図**を参照して、前面ラック・レールの適当な穴を選んで固定部を取付けます。

2. 下記方法のどちらかを用いて、スライドアウト・トラックの固定部を前面ラック・レールに取付けます。

(a) 固定部の前面フランジを前面レールの後に取付ける場合（レールを埋込むか、雌ねじを切っていない）、固定部は**2-2(A)図**右に示すように取付けて下さい。

(b) 固定部の前面フランジを前面レールの前に取付ける場合（レールには10-32UNFねじ用の雌ねじを切っている）、**2-2(B)図**右に示すように固定部を取付けて下さい。ねじ頭が前面フランジをレールに固定できるように、支持面を増やすために、ねじ頭の下に平ワッシャ（付属していません）を加えることもできます。

しかし、この方法を使用すると、固定部とワッシャとの厚味のために、前面パネルと前面レールとが揃いません。両者を揃えたい時には、1(a)の方法をお奨めします。

3. スライドアウトの固定部を下記の方法のどちらかによって、後部ラック・レールに取付けます。

(a) 後部ラック・レールの穴に10-32UNFねじ用の雌ねじを切っていない場合には、**2-2 A図**の中央左に示すように、付属の金具を使って、左側の固定部を取付けます。後部取付ブラケットは、キャビネット・ラックの奥行に応じてスライドアウト・トラックを取付けることができるようにどちらの向きにも取付けることができます。

右側の固定部を取付ける際には、**2-2 A図**に従って下さい。固定部が水平に調節され、左右が平行になっていることを確認します。

(b) 後部ラック・レールの穴に10-32ユニファイねじ用の雌ねじが切られている場合には、**2-2(B)図**中央または左に示すように、付属の金具を使って左側固定部を取付けます。後部取付ブラケットはキャビネットラックの奥行に応じて、スライドアウト・トラックを

取付けることができるように、どちらの向きにも取付けることができます。右側の固定部を取付ける際には**2-2(B)図**を手引きとして用います。固定部が水平に調節され、左右が平行になっていることを確認します。

### TM506型の取付けと調整

機器をラックに挿入するには下記の手順に従って下さい。

1. スライドアウト・トラックの中間部を完全に延びきった位置まで引き出します。

2. 機器のシャーシ部を中間部に挿入します。

3. シャーシ部のストップ・ラッチを押しラッチが穴に食い込むまで機器をラックに押込みます。

4. 再びストップ・ラッチを押し、機器をラックに押込みます。

スライドアウト・トラックが滑らかにスライド動作をするように調節するには、固定部をラックのレールに固定しているねじをゆるめます。機器を中央に合せ、スライドアウト・トラックの適正な幅にセットし、ねじを締めます。

機器の前面パネルをラックに固定するためには、ラックにユニバーサル規格の穴間隔で穿孔してあるか、新しく穴をあけて10-32ユニファイねじ用の雌ねじを切る必要があります。（**2-3図**参照）**2-3図**に示す金具（付属していません）を使って、**TM506型**をラックの前面レールに取付けます。

### スライドアウト・トラックの保守

スライドアウト・トラックには注油の必要はありません。スライド部の特殊なダーク・グレイ仕上げは、永久潤滑です。

## **WARNING**

THE FOLLOWING SERVICING INSTRUCTIONS ARE FOR USE BY QUALIFIED PERSONNEL ONLY. TO AVOID PERSONAL INJURY, DO NOT PERFORM ANY SERVICING OTHER THAN THAT CONTAINED IN OPERATING INSTRUCTIONS UNLESS YOU ARE QUALIFIED TO DO SO.



# MAINTENANCE

## GENERAL

### Introduction

This section of the manual is meant to support the entire TM 500 Series family of modules with a general coverage of the most commonly-needed service information pertinent to preventive maintenance, troubleshooting, ordering parts, and replacing components and sub-assemblies.

### Cabinet Removal

#### WARNING

*Dangerous potentials exist at several points throughout the system. When the system must be operated with the cabinet removed, do not touch exposed connections or components. Some transistors have voltage present on their cases. Disconnect power before cleaning the system or replacing parts.*

Six screws on the top secure the cabinet to the TM 506 frame. Remove them and lift the cabinet straight up. Do not operate the system with the cabinet removed any longer than necessary for troubleshooting and calibration. Re-install the cabinet to protect the interior from dust and to remove personnel shock hazards.

### Cleaning

#### CAUTION

*Avoid using chemical cleaning agents which might damage plastic parts. Avoid chemicals containing benzene, toluene, xylene, acetone, or similar solvents.*

**Air Filter.** The air filter should be visually checked every few weeks and cleaned or replaced if dirty. More frequent inspections are required under severe operating conditions. If the filter is to be replaced, order new filters from your local Tektronix Field Office or representative; order by Tektronix Part 378-0810-00. The following procedure is suggested for cleaning the filter.

1. Remove the filter by pulling it out of the retaining frame on the rear panel. Be careful not to drop any of the accumulated dirt into the instrument.

2. Flush the loose dirt from the filter with a stream of hot water.

3. Place the filter in a solution of mild detergent and hot water and let soak for several minutes.

4. Squeeze the filter to wash out any dirt which remains.

5. Rinse the filter in clean water and let dry.

6. Coat the dry filter with an air-filter coating (available from air conditioner suppliers or order Tektronix Part 006-0580-00).

7. Let the filter thoroughly dry.

8. Reinstall the filter in the retaining frame.

**Exterior.** Loose dust may be removed with a soft cloth or a dry brush. Water and a mild detergent may be used. However, abrasive cleaners should not be used.

**Interior.** Cleaning the interior of a unit should precede calibration since the cleaning processes could alter the settings of calibration adjustments. Use low-velocity compressed air to blow off accumulated dust. Hardened dirt can be removed with a soft brush, cotton-tipped swab, or a cloth dampened in a solution of water and mild detergent.

### Preventive Maintenance

Preventive maintenance steps performed on a regular basis will enhance the reliability of the instrumentation systems. However, periodic checks of the semiconductors in the absence of a malfunction are not recommended as preventive maintenance measures. See the semiconductor checking information under Troubleshooting Techniques which follow. A convenient time to perform preventive maintenance is just before instrument calibration.

### Calibration

To ensure accurate signal generation and measurement, the performance of individual units comprising the system should be checked periodically. Refer to the Instruction Manual for each unit for complete calibration and verification procedures.

## TROUBLESHOOTING AIDS

### Introduction

The following is provided to augment information contained elsewhere in this and other TM 500 series family manuals when troubleshooting becomes necessary.

### Circuit Description

Each manual has a section devoted to explaining circuit operating theory. Used conjointly with the schematics, this can be a powerful analytic tool.

### Diagrams

Block diagrams and detailed circuit schematics are located on foldout pages in the service section of most of the TM 500 Series family manuals. The schematic diagrams show the component values and assigned circuit reference numbers of each part necessary to the circuit design. Usually the first page of the service section defines the circuit symbols and reference designators used in that particular instrument. Major circuits are usually identifiable by a series of component numbers. Important waveforms and voltages may be shown within the diagrams or on adjoining aprons. Those portions of the circuits located on circuit boards are enclosed with a blue tint outline.

### Cam Switch Charts

Cam switches shown on the diagrams are coded on comprehensive charts to locate the cam number of the switch contact in the complete switch assembly, counting from the front, or knob end, toward the rear of the switch. The charts also indicate with a solid dot when each contact is closed.

### Circuit Board Illustrations

Line illustrations showing component locations keyed with a grid scheme for each circuit board are usually placed on the back of a foldout page and sequenced as close as possible to an associated schematic. The GRID LOC columns, located near the Parts Location Grid, keys each component to easy location on the board.

### Component and Wiring Color Codes

Colored stripes or dots on electrical components signify electrical values, tolerances, etc., according to EIA standards. Components not color-coded usually have information printed on the body. The wiring coding follows the same EIA standards with the exception of the ac power cord of the Power Modules. It is coded like this:

### Power Cord Conductor Identification

Conductor	Color	Alternate Color
Ungrounded (Line)	Brown	Black
Grounded (Neutral)	Blue	White
Grounding (Earthing)	Green-Yellow	Green-Yellow

### Testing Equipment

Generally, a wide-band oscilloscope, a probe, and a multimeter are all that is needed to perform basic waveform and voltage checks for diagnostic purposes. The calibration procedures in the manual for each plug-in module list specific test equipment and the features necessary to adequately check out that particular module.

## TROUBLESHOOTING TECHNIQUES

### Introduction

This troubleshooting procedure is arranged in an order which checks the simple trouble possibilities before proceeding to extensive troubleshooting.

### Control Settings

Incorrect control settings can indicate a trouble that does not exist. If there is any question about the correct function or operation of any control, see the Operating Instructions section of the manual for the instrument involved.

### System and Associated Equipment

Before proceeding with troubleshooting the TM 500 Series system, check that the instruments in the system are operating correctly. Check for proper interconnection between the power module and the plug-in modules. Check the line voltage at the power source. Check that the signal is properly connected and that the interconnecting cables and signal source are not defective.

The associated plug-in modules can be checked for proper operation quickly by substituting other like units known to be operating properly. If the trouble persists

after substitution, then the power module is probably at fault. Moving a properly operating plug-in from compartment to compartment will help determine if one or more compartments have a problem.

### Visual Check

Inspect the portion of the system in which the trouble is suspected. Many troubles can be located by visual clues such as unsoldered connections, broken wires, damaged circuit board, damaged components, etc.

### Instrument Calibration

Check the calibration of the suspected plug-in module or the affected circuit if the trouble is obviously in a certain circuit. The trouble may only be a result of misadjustment or may be corrected by re-calibration. Complete calibration instructions are given in the manual for each instrument in the system.

### Circuit Isolation

Note the trouble symptoms. These often identify the circuit in which the trouble is located. When trouble symptoms appear in more than one circuit, check the affected circuits by making waveform and voltage measurements.

Incorrect operation of all circuits often means trouble in the power supplies. Using a multimeter, check first for correct voltages of the individual regulated supplies according to the plug-in module schematics and calibration procedures. Then check the unregulated supplies of the power modules. Defective components elsewhere in the instruments can appear as power supply problems. In these instances, suspected circuits should be disconnected from apparently bad power supplies one at a time to narrow the search.

### Voltages and Waveforms

Often defective components can be located by using waveform and voltage indications when they appear on the schematic or in the calibration procedures. Such waveforms and voltage labels are typical indications and will vary between instruments. To obtain operating conditions similar to those used to take these readings, refer to the first diagram in the service sections.

### Component Checking

If a component cannot be disconnected from its circuit, then the effects of the associated circuitry must be considered when evaluating the measurement. Except for soldered-in transistors and integrated circuits, most components can be lifted at one end from the circuit board.

**Transistors and IC's.** Turn the power switch off before removing or replacing any semiconductor.

A good check of transistor IC operation is actual performance under operating conditions. A transistor can most effectively be checked by substituting a new component for it (or one which has been checked previously). However, be sure that circuit conditions are not such that a replacement transistor might also be damaged. If substitute transistors are not available, use a dynamic tester. Static-type testers are not recommended, since they do not check operation under simulated operating conditions. A suction-type desoldering tool must be used to remove soldered-in transistors; see component replacement procedure for details.

Integrated circuits can be checked with a voltmeter, test oscilloscope, or by direct substitution. A good understanding of the circuit description is essential to troubleshooting circuits using IC's. Operating waveforms, logic levels, and other operating information for the IC's are given in the circuit description information of the appropriate manual. Use care when checking voltages and waveforms around the IC's so that adjacent leads are not shorted together. A convenient means of clipping a test probe to the 14- and 16-pin in-line IC's is with an integrated circuit test clip. This device also doubles as an extraction tool.

**Diodes.** Do not use an ohmmeter that has a high internal current. High currents may damage the diode.

A diode may be checked for an open or shorted condition by measuring the resistance between terminals. With an ohmmeter scale having an internal source of between 800 mV, and 3 V, the resistance should be very high in one direction and very low when the leads are reversed.

**Resistors.** Check the resistors with an ohmmeter. Resistor tolerances are given in the Electrical Parts List in every manual. Resistors do not normally need to be replaced unless the measured value varies widely from the specified value.

**Capacitors.** A leaky or shorted capacitor can be detected by checking resistance with an ohmmeter on the highest scale. Use an ohmmeter that will not exceed the voltage rating of the capacitor. The resistance reading should be high after initial charge of the capacitor. An open capacitor can best be detected with a capacity meter, or by checking whether it passes ac signals.

## PARTS ORDERING AND REPLACING

### Ordering

**Obtaining Replacement Parts.** Most electrical and mechanical parts can be obtained through your local Tektronix field office or representative. However, you should be able to obtain many of the standard electronic components from a local commercial source in your area. Before you purchase or order a part from a source other than Tektronix Inc., please check the electrical parts list for the proper value, rating, tolerance and description.

**Special Parts.** Some parts are manufactured or selected by Tektronix, Inc. to satisfy particular requirements, or are manufactured for Tektronix, Inc., to our specifications. Most of the mechanical parts used in this system have been manufactured by Tektronix, Inc. Order all special parts directly from the local Tektronix Field Office or representative.

**Ordering Procedure.** When ordering replacement parts from Tektronix, Inc., please include the following minimum information:

1. Instrument Type (PS 501, SG 502, DC 501, etc.)
2. Instrument Serial Number (For example, B010251)
3. A description of the part (if electrical include the circuit number)
4. Tektronix part number

Please do not return any instruments or parts before receiving directions from Tektronix, Inc.

A listing of Tektronix Field Offices, Service Center and Representatives can be found in the Tektronix Product Catalog and Supplements.

### Replacing

The exploded view drawings associated with the Mechanical Parts List, located to the rear of most manuals, may be especially helpful when disassembling or reassembling individual components or sub-assemblies.

**Circuit Boards.** If a circuit board is damaged beyond repair, either the entire assembly including all soldered-on components, or the board only, can be replaced.

To remove or replace a board, proceed as follows:

1. Disconnect all leads connected to the board (both soldered lead connections and solderless pin connections).
2. Remove all screws holding the board to the chassis or other mounting surface. Some boards may be held fast by plastic mounting clips around the board edges. For these, push the mounting clips away from the circuit board edges to free the board. Also, remove any knobs, etc., that would prevent the board from being lifted out of the instrument.
3. Lift the circuit board out of the unit. Do not force or bend the board.
4. To replace the board, reverse the order of removal. Use care when replacing pin connectors. If forced into place incorrectly positioned, the pin connectors may be damaged.

**Transistors and IC's.** Transistors and IC's should not be replaced unless they are actually defective. If removed from their sockets during routine maintenance, return them to their original sockets. Unnecessary replacement or switching of semiconductor devices may affect the calibration of the instruments. When a transistor is replaced, check the operation of the part of the instrument that may be affected.

Replacement semiconductors should be of the original type or a direct replacement. Figure 3-1 shows the lead configurations of the semiconductors used in this instrument system. When removing soldered-in transistors, use a suction-type desoldering tool to remove the solder from the holes in the circuit board.

An extracting tool should be used to remove the 14- and 16-pin integrated circuits to prevent damage to the pins. This tool is available from Tektronix, Inc. Order Tektronix Part No. 003-0619-00. If an extracting tool is not available, use care to avoid damaging the pins. Pull slowly and evenly on both ends of the IC. Try to avoid having one end of the IC disengage from the socket before the other end.

To replace one of the power transistors mounted on the Power Module chassis adjacent to the interface circuit board, first unsolder the leads. Then, loosen the nuts which clamp the transistor to the chassis. Remove the defective transistor. When replacing the transistor, use a mica washer on the metal tab to increase heat transfer from the transistor to the chassis.

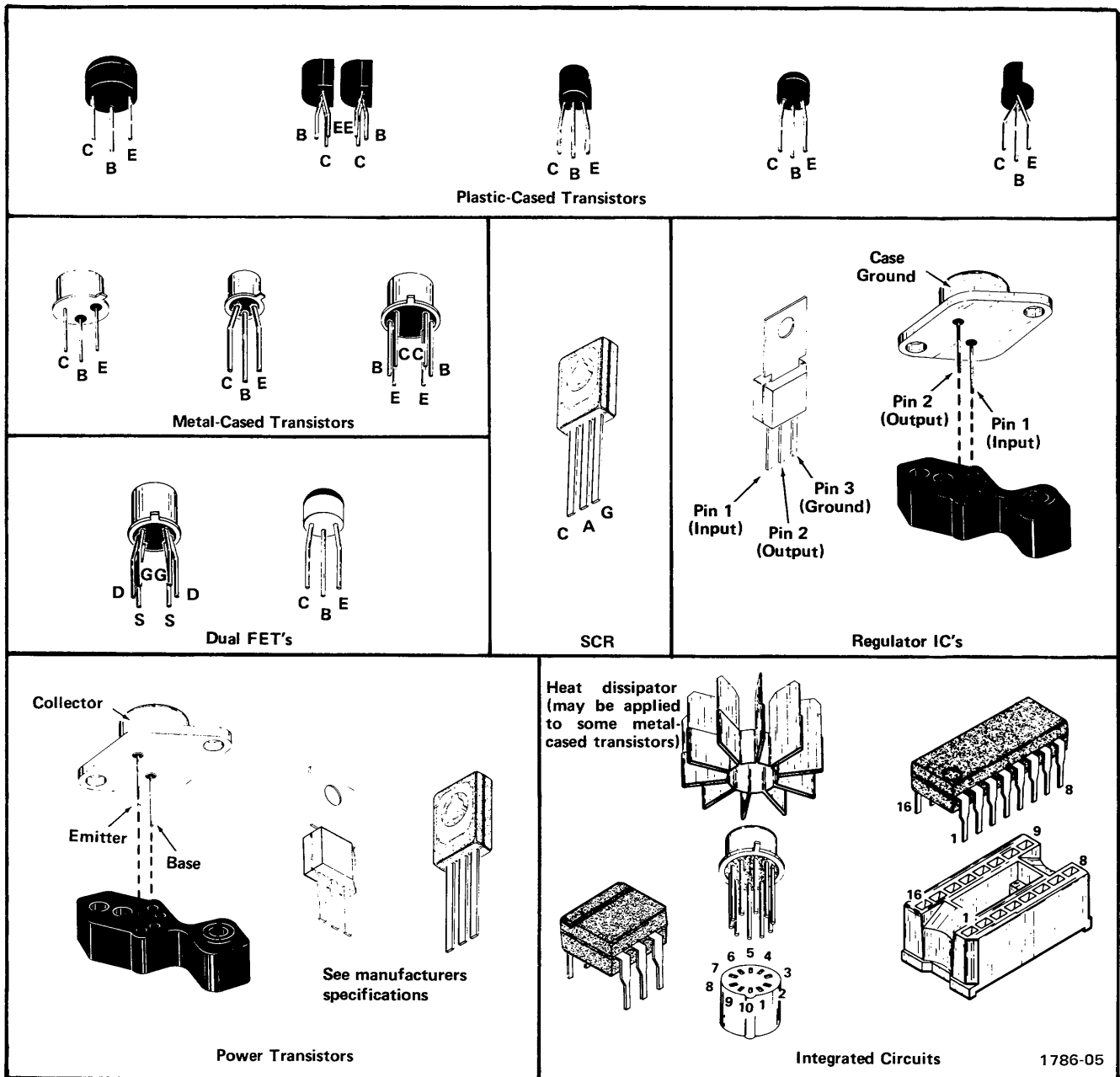

Fig. 3-1. Semiconductor device lead configurations found in the TM 500 family.

**Static-Sensitive Components**



*Static discharge can damage any semiconductor component in this instrument.*

This instrument contains electrical components that are susceptible to damage from static discharge. See Table 3-1 for relative susceptibility of various classes of semiconductors. Static voltages of 1 kV to 30 kV are common in unprotected environments.

Observe the following precautions to avoid damage:

1. Minimize handling of static-sensitive components.
2. Transport and store static-sensitive components or assemblies in their original containers, on a metal rail, or on conductive foam. Label any package that contains static-sensitive assemblies or components.
3. Discharge the static voltage from your body by wearing a wrist strap while handling these components.

Servicing static-sensitive assemblies or components should be performed only at a static-free work station by qualified service personnel.

4. Nothing capable of generating or holding a static charge should be allowed on the work station surface.
5. Keep the component leads shorted together whenever possible.
6. Pick up components by the body, never by the leads.
7. Do not slide the components over any surface.
8. Avoid handling components in areas that have a floor or work surface covering capable of generating a static charge.
9. Use a soldering iron that is connected to earth ground.
10. Use only special antistatic suction type or wick type desoldering tools.

**Test Equipment**

Before using any test equipment to make measurements on static-sensitive components or assemblies, be certain that any voltage or current supplied by the test equipment does not exceed the limits of the component to be tested.

**Table 3-1  
RELATIVE SUSCEPTIBILITY TO  
STATIC DISCHARGE DAMAGE**

Semiconductor Classes	Relative Susceptibility Levels <sup>a</sup>
MOS or CMOS microcircuits or discretes, or linear microcircuits with MOS inputs (Most Sensitive)	1
ECL	2
Schottky signal diodes	3
Schottky TTL	4
High-frequency bipolar transistors	5
JFETs	6
Linear Microcircuits	7
Low-power Schottky TTL	8
TTL (Least Sensitive)	9

<sup>a</sup>Voltage equivalent for levels:

- |                  |                  |                          |
|------------------|------------------|--------------------------|
| 1 = 100 to 500 V | 4 = 500 V        | 7 = 400 to 1000 V (est.) |
| 1 = 200 to 500 V | 5 = 400 to 600 V | 8 = 900 V                |
| 3 = 250 V        | 6 = 600 to 800 V | 9 = 1200 V               |

(Voltage discharged from a 100 pF capacitor through a resistance of 100 ohms.)

**Interconnecting Pins.** To replace a pin that is mounted on a circuit board, first disconnect any pin connectors. Then, unsolder the damaged pin and pull it out of the board with a pair of pliers. Be careful not to damage the wiring on the board with too much heat. Ream out the hole in the circuit board with a 0.031-inch drill. Remove the ferrule from the new interconnecting pin and press the new pin into the hole in the circuit board. Position the pin in the same manner as the old pin and solder it in. If the old pin was bent at an angle to mate with a connector, bend the new pin to match the associated pins.

**NOTE**

*A pin replacement kit including necessary tools, instructions, and replacement pins is available from Tektronix, Inc. Order Tektronix Part No. 040-0542-00.*

**Option 2**

This factory installed option adds 25-mil square pin connectors to the rear of the interconnecting jacks at all pin locations from pins 14A and B. This will keep the interface flexible by making it easy and fast to change customized wiring using prepared wires with square pin receptacles. It also protects the circuit board from damage by repeating soldering and unsoldering of jumper wires. This option also adds six BNC connectors and one 50-pin connector to the rear panel. These connectors are not prewired in order to give a system designer as much flexibility as possible. Instead, prepared jumpers, coax cables, and interconnection jack barriers are included in the TM 506.

**System Design Directions**

1. Plan the plug-in location based on the front-panel controls and operator convenience as well as interface connections.
2. Plan the wiring between interconnecting jacks and to the rear panel connectors carefully before starting assembly. A mating rear panel 50-pin connector and cover are provided for external cabling.

**NOTE**

*There are no pin assignments for the rear panel connectors, due to the great variety of possible connections.*

*When high frequency or fast digital signals are involved, plan the wires so as to minimize crosstalk. Make allowance for the possible need to make auxiliary ground connections.*



The 50-pin rear panel connector may be easier to connect if it is removed from the rear panel and remounted after connections are made. Remove the top rear cabinet piece for ease of access.

If more than 50 pins are needed, an AMP HD-22 series connector with 104 pins may be mounted in the same cut out. It is suggested that these parts be obtained directly from AMP Inc., Harrisburg, PA or their distributors. For further application information, contact Tektronix' TM 500 Marketing Group, Beaverton, OR.

3. Pin assignments for individual plug-ins will be found in the appropriate instruction manual.

4. Install an interconnection jack barrier at the appropriate location on the interconnection jack. Refer back to operating instructions for keying assignments for family functions.

5. Select and install the wires (hook-up or coax) following the guidelines in the Wire Use part of these instructions.

6. Wires or cables which may be at large potential differences should be dressed or bundled so as to avoid contact. Keep all interface wiring away from the TM 506 primary line wiring.

7. There is an empty cut-out which will mount the standard IEC digital interface connector. The connector is not supplied with this option.

### Wire Use

1. Hook up wire with square-pin receptacle on both ends. These may be used for low-frequency or dc circuits where impedance levels and crosstalk are not a problem. The wire is supplied in four lengths for connection between compartments (adjacent or non-adjacent) or between a compartment and the rear panel. For connection to the rear panel, cut to length then tin and solder the end going to the rear panel.

2. Coaxial wire with square pin receptacles on both ends. These are used for connections which require shielding or which must maintain a 50 ohm characteristic impedance. The outer conductor should be connected to either chassis ground or circuit ground. Plug-in lines which require coax leads usually have a specified ground pin assignment. If necessary, establish auxiliary ground connections at the appropriate wire ends. The coaxial wire is supplied in four lengths for connection between com-

partments (adjacent or non-adjacent) or between a compartment and the rear panel. For connection to the rear panel, cut to length then tin and solder the end going to the rear panel.

### Option 7

The following described bus wires and keys are added to the connector boards of the TM 500-Series Power Module to provide rear interface connections between the TM 500 Counters containing Option 7, the TR 502, and the SW 503.

**Bus Wires.** Six-conductor ribbon cable (Tektronix Part No. 175-0829-00) is used to make bus runs between the following points:

TM 506

B14 on J10, J20, and J30  
 B15 on J10, J20, and J30  
 B16 on J10, J20, and J30  
 B17 on J10, J20, and J30  
 B18 on J10, J20, and J30  
 A18 on J10, J20, and J30

**Barrier Keys.** Plastic barrier keys (Tektronix Part No. 214-1593-02) are inserted between pins 21 and 22 on J10 between pins 23 and 24 on J20 and between pins 17 and 18 on J30.

Once the above bus connections are made and barrier keys inserted, the three connectors so changed are system dedicated and the three slots should only be used for system-dedicated plug-ins.

**Cam Switches.** Repair of cam-type switches should be undertaken only by experienced maintenance personnel. Switch alignment and spring tension of the contacts must be carefully maintained for proper operation of the switch. For assistance, contact your local Tektronix Field Office or representative.

### NOTE

*A cam-type switch repair kit including necessary tools, instructions, and replacement contacts is available from Tektronix, Inc. Order Tektronix Part No. 040-0541-00.*

The cam-type switches consist of rotating cam drums which are turned by front-panel knobs, and sets of spring-leaf contacts mounted on adjacent circuit boards. The contacts are actuated by lobes on the cams. These switches can be disassembled for inspection, cleaning, repair, or replacement as follows:

1. Remove the screws which hold the metal cover on the switch, and lift the cover off the switch. The switch is now open for inspection or cleaning.

2. To completely remove a switch from the circuit board, first remove any knobs or shaft extensions. Loosen the coupling at the potentiometer at the rear of the switch, and pull the long shaft out of the switch assembly.

3. Remove the screws (from the opposite side of the circuit board) that holds the cam drum to the board.

4. To remove the cam drum from the front support block, remove the retaining ring from the shaft on the front of the switch and slide the cam drum out of the support block. Be careful not to lose the small detent roller.

5. To replace defective switch contacts, follow the instructions given in the switch repair kit.

6. To re-install the switch assembly, reverse the above procedure.

**Pushbutton Switches.** The pushbutton switches are not repairable and should be replaced as a unit if defective. Use a suction-type de-soldering tool to remove solder from the circuit board when removing these switches.

**Incandescent Bulbs.** Most of these light bulbs are mounted on the sub-panel using plastic sleeve stand-offs. Unsolder the lead wires and pull the bulb out of the sleeve from the rear of the sub-panel.

**Light-Emitting Diodes.** LED's used as indicators are mounted on the sub-panels with plastic sleeve sockets similar to the incandescent bulb mountings or they are

soldered directly to a sub-assembly and so mounted that they protrude through holes in the panel. In these cases, the sub-assembly must be exposed and the anode and cathode lead orientations carefully noted before unsoldering the defective LED. See Fig. 3-2 for LED lead identifying information.

**Power Transformer.** Replace the transformer only with a Tektronix direct replacement transformer. Refer to the exploded view drawing at the rear of the Power Module manuals for disassembly of the rear panel to expose the power transformer. Refer to the schematic diagram color-coding information for correct wiring. After replacement check out the power supply voltages before installing a plug-in module.

**Packaging Information**

A list of standard accessories (and part numbers) is located in the Replaceable Mechanical Parts list.

If the Tektronix instrument is to be shipped to a Tektronix Service Center for service or repair, attach a tag showing owner (with address) and the name of an individual at your firm that can be contacted. Include the complete instrument serial number and a description of the service required.

Save and re-use the package in which your instrument was shipped. If the original packaging is unfit for use or not available, repackage the instrument as follows:

Surround the instrument with polyethylene sheeting to protect the finish of the instrument. Obtain a carton of corrugated cardboard of the correct carton strength and having inside dimensions of no less than 6 inches more than the instrument dimensions. Cushion the instrument by tightly packing 3 inches of dunnage or

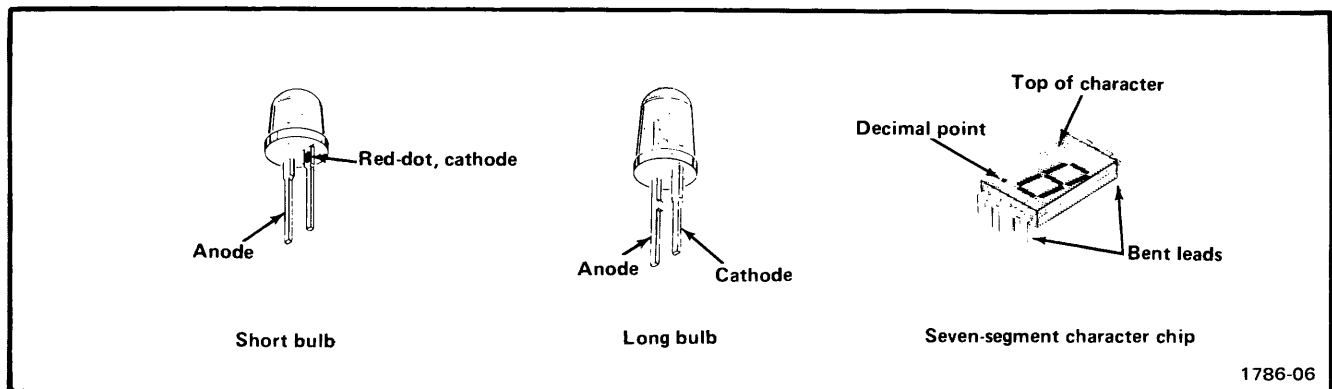

Fig. 3-2. Light-emitting diode (LED) lead orientation illustration.

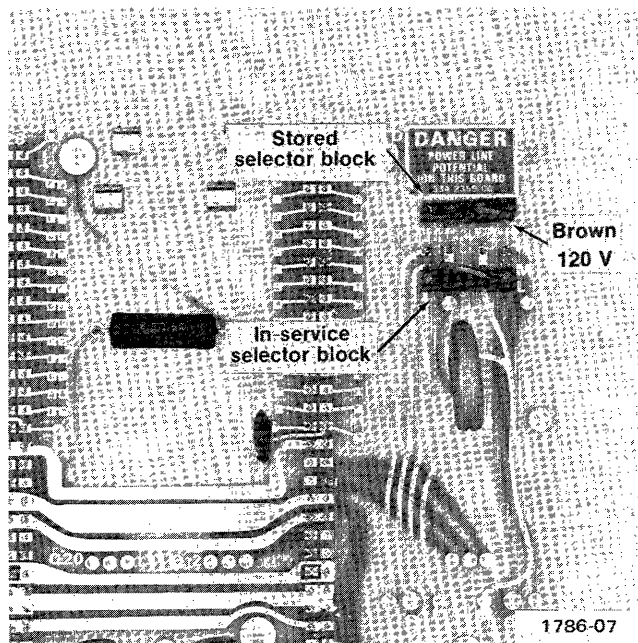

Fig. 3-3. 220 V Selector block in service.

urethane foam between carton and instrument on all sides. Seal the carton with shipping tape or an industrial stapler.

The carton test strength for this instrument is 375 pounds per square inch.

## INSTALLATION PROCEDURE

Due to regional variations in the power source line voltage the TM 506 has selectable transformer primary taps. The taps are located on the interface board and are implemented by using the appropriate selector block. See Figs. 3-3, 3-4, and 3-5.

Table 3-2 shows which position the selector block should be in for specific line voltages. The brown selector block should be used for nominal line voltages of 120 V, and the red selector block for 220 V nominal line voltages. For example, if the power source is 120 V nominal and

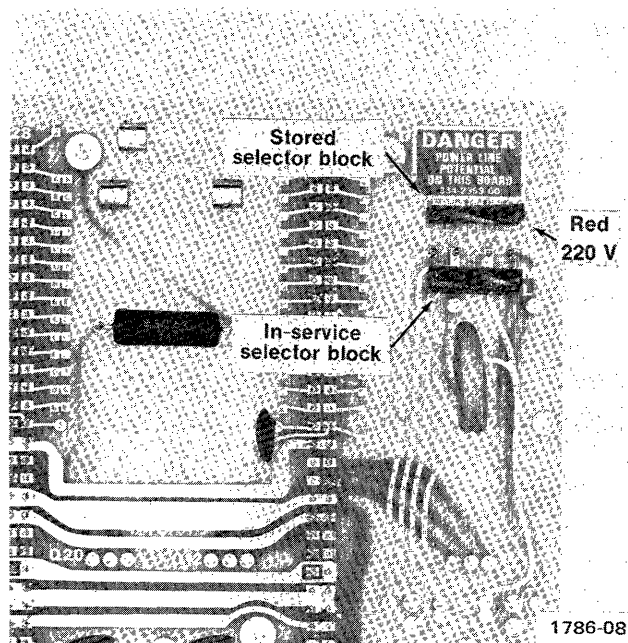

Fig. 3-4. 120 V Selector block in service.

To determine how the TM 506 is set and if a change is necessary, the following procedure should be used:

1. Determine what the actual line voltage of the power source is and note.
2. Remove the six hold-down screws on the top of the dust cover cabinet and lift off.
3. Locate and determine the position of the line selector block.



**Maintenance—TM 506/RTM 506**

4. Using the above noted line voltage and Table 3-2, determine if a change is necessary.

5. If a change is necessary place the selector block on the appropriate taps. If no change is needed go on to the next step.

6. Replace the cabinet and hold-down screws.

7. Check the SET FOR VAC indicator where the power cord enters the back panel (see Fig. 3-6), using the settings given below.

For 120 V nominal:

- L — 100
- M — 110
- H — 120

For 220 V nominal:

- L — 200
- M — 220
- H — 240

Using the example given above, the indicator would be set at 120. The indicator is set by pulling the numbered ring away from the instrument, turning so

that the appropriate number will appear in the slot, and pressing towards the instrument.

8. The instrument is now ready for use.

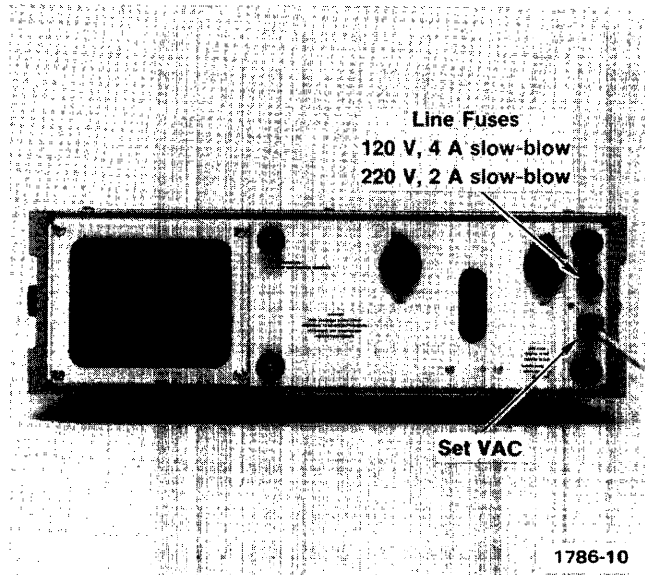

**Fig. 3-6. Line voltage set indicator.**

# OPTIONS

Your instrument may be equipped with Option 2, which allows customizing of the interface. Detailed information concerning this option may be found in the following sections:

Section 2 — Operating Instructions

Section 3 — Maintenance

Section 7 — Replaceable Mechanical Parts

Your instrument may be equipped with Option 7, which allows the instrument to be used with plug-ins containing Option 7. Detailed information concerning this option may be found in Section 3 — Maintenance.

# REPLACEABLE ELECTRICAL PARTS

## PARTS ORDERING INFORMATION

Replacement parts are available from or through your local Tektronix, Inc. Field Office or representative.

Changes to Tektronix instruments are sometimes made to accommodate improved components as they become available, and to give you the benefit of the latest circuit improvements developed in our engineering department. It is therefore important, when ordering parts, to include the following information in your order: Part number, instrument type or number, serial number, and modification number if applicable.

If a part you have ordered has been replaced with a new or improved part, your local Tektronix, Inc. Field Office or representative will contact you concerning any change in part number.

Change information, if any, is located at the rear of this manual.

## SPECIAL NOTES AND SYMBOLS

X000 Part first added at this serial number  
00X Part removed after this serial number

## ITEM NAME

In the Parts List, an Item Name is separated from the description by a colon (:). Because of space limitations, an Item Name may sometimes appear as incomplete. For further Item Name identification, the U.S. Federal Cataloging Handbook H6-1 can be utilized where possible.

## ABBREVIATIONS

ACTR	ACTUATOR	PLSTC	PLASTIC
ASSY	ASSEMBLY	QTZ	QUARTZ
CAP	CAPACITOR	RECP	RECEPTACLE
CER	CERAMIC	RES	RESISTOR
CKT	CIRCUIT	RF	RADIO FREQUENCY
COMP	COMPOSITION	SEL	SELECTED
CONN	CONNECTOR	SEMICOND	SEMICONDUCTOR
ELCTLT	ELECTROLYTIC	SENS	SENSITIVE
ELEC	ELECTRICAL	VAR	VARIABLE
INCAND	INCANDESCENT	WW	WIREWOUND
LED	LIGHT EMITTING DIODE	XFMR	TRANSFORMER
NONWIR	NON WIREWOUND	XTAL	CRYSTAL

CROSS INDEX—MFR. CODE NUMBER TO MANUFACTURER

Mfr. Code	Manufacturer	Address	City, State, Zip
01121	ALLEN-BRADLEY COMPANY	1201 2ND STREET SOUTH	MILWAUKEE, WI 53204
04713	MOTOROLA, INC., SEMICONDUCTOR PROD. DIV.	5005 E MCDOWELL RD, PO BOX 20923	PHOENIX, AZ 85036
56289	SPRAGUE ELECTRIC CO.		NORTH ADAMS, MA 01247
71400	BUSSMAN MFG., DIVISION OF MCGRAW-EDISON CO.	2536 W. UNIVERSITY ST.	ST. LOUIS, MO 63107
72982	ERIE TECHNOLOGICAL PRODUCTS, INC.	644 W. 12TH ST.	ERIE, PA 16512
73803	TEXAS INSTRUMENTS, INC., METALLURGICAL MATERIALS DIV.	34 FOREST STREET	ATTLEBORO, MA 02703
80009	TEKTRONIX, INC.	P O BOX 500	BEAVERTON, OR 97077
82877	ROTRON, INC.	7-9 HASBROUCK LANE	WOODSTOCK, NY 12498
91637	DALE ELECTRONICS, INC.	P. O. BOX 609	COLUMBUS, NE 68601
91929	HONEYWELL, INC., MICRO SWITCH DIV.	CHICAGO & SPRING STS.	FREEPORT, IL 61032
95238	CONTINENTAL CONNECTOR CORP.	34-63 56TH ST.	WOODSIDE, NY 11377

Ckt No.	Tektronix Part No.	Serial/Model No. Eff	Dscont	Name & Description	Mfr Code	Mfr Part Number
A1	670-3303-00	B010100	B029999	CKT BOARD ASSY:INTERFACE	80009	670-3303-00
A1	670-3303-01	B030000		CKT BOARD ASSY:INTERFACE	80009	670-3303-01
A1A	670-3984-00	B010100	B029999	CKT BOARD ASSY:INTERFACE	80009	670-3984-00
	-----			(OPTION 2 ONLY)		
A1A	670-3984-01	B030000		CKT BOARD ASSY:INTERFACE	80009	670-3984-01
	-----			(OPTION 2 ONLY)		
A2	670-3834-00			CKT BOARD ASSY:FILTER	80009	670-3834-00
B4	119-0026-00			FAN,AXIAL:1.500 X 4.750 INCH,WHISPER	82877	WR2A1
B4	119-0147-00			FAN,AXIAL:115V,50-60HZ,14W	82877	028021
	-----			(RACKMOUNT ONLY)		
C2	283-0022-00			CAP.,FXD,CER DI:0.02UF,1400VDCAC	80009	283-0022-00
C10	283-0004-00			CAP.,FXD,CER DI:0.02UF,+80-20%,150V	72982	855-558Z5V0203Z
C11	290-0637-00			CAP.,FXD,ELCTLT:5000UF,+45-10%,50V	56289	68D10527
C12	290-0637-00			CAP.,FXD,ELCTLT:5000UF,+45-10%,50V	56289	68D10527
C20	283-0004-00			CAP.,FXD,CER DI:0.02UF,+80-20%,150V	72982	855-558Z5V0203Z
C21	290-0637-00			CAP.,FXD,ELCTLT:5000UF,+45-10%,50V	56289	68D10527
C22	290-0637-00			CAP.,FXD,ELCTLT:5000UF,+45-10%,50V	56289	68D10527
C30	283-0004-00			CAP.,FXD,CER DI:0.02UF,+80-20%,150V	72982	855-558Z5V0203Z
C31	283-0004-00			CAP.,FXD,CER DI:0.02UF,+80-20%,150V	72982	855-558Z5V0203Z
C32	283-0004-00			CAP.,FXD,CER DI:0.02UF,+80-20%,150V	72982	855-558Z5V0203Z
C33	290-0508-00			CAP.,FXD,ELCTLT:18,000UF,+100-10%,15V	56289	68D10444
C35	290-0508-00			CAP.,FXD,ELCTLT:18,000UF,+100-10%,15V	56289	68D10444
C39	283-0004-00			CAP.,FXD,CER DI:0.02UF,+80-20%,150V	72982	855-558Z5V0203Z
C40	283-0004-00			CAP.,FXD,CER DI:0.02UF,+80-20%,150V	72982	855-558Z5V0203Z
C41	283-0004-00			CAP.,FXD,CER DI:0.02UF,+80-20%,150V	72982	855-558Z5V0203Z
C42	283-0004-00			CAP.,FXD,CER DI:0.02UF,+80-20%,150V	72982	855-558Z5V0203Z
C43	283-0004-00			CAP.,FXD,CER DI:0.02UF,+80-20%,150V	72982	855-558Z5V0203Z
C44	283-0004-00			CAP.,FXD,CER DI:0.02UF,+80-20%,150V	72982	855-558Z5V0203Z
C46	283-0004-00			CAP.,FXD,CER DI:0.02UF,+80-20%,150V	72982	855-558Z5V0203Z
C50	283-0004-00			CAP.,FXD,CER DI:0.02UF,+80-20%,150V	72982	855-558Z5V0203Z
C51	283-0004-00			CAP.,FXD,CER DI:0.02UF,+80-20%,150V	72982	855-558Z5V0203Z
C52	283-0004-00			CAP.,FXD,CER DI:0.02UF,+80-20%,150V	72982	855-558Z5V0203Z
C55	290-0508-00			CAP.,FXD,ELCTLT:18,000UF,+100-10%,15V	56289	68D10444
C60	283-0004-00			CAP.,FXD,CER DI:0.02UF,+80-20%,150V	72982	855-558Z5V0203Z
C60	283-0004-00			CAP.,FXD,CER DI:0.02UF,+80-20%,150V	72982	855-558Z5V0203Z
CR10	152-0198-01			SEMICONV DEVICE:RECT,SI,200V,3A	04713	1N4721
CR11	152-0198-01			SEMICONV DEVICE:RECT,SI,200V,3A	04713	1N4721
CR12	152-0198-01			SEMICONV DEVICE:RECT,SI,200V,3A	04713	1N4721
CR13	152-0198-01			SEMICONV DEVICE:RECT,SI,200V,3A	04713	1N4721
CR30	152-0274-00			SEMICONV DEVICE:SILICON,100V,10A	80009	152-0274-00
CR32	152-0274-00			SEMICONV DEVICE:SILICON,100V,10A	80009	152-0274-00
CR50	152-0274-00			SEMICONV DEVICE:SILICON,100V,10A	80009	152-0274-00
CR52	152-0274-00			SEMICONV DEVICE:SILICON,100V,10A	80009	152-0274-00
F2	159-0023-00	XB017520		FUSE,CARTRIDGE:3AG,2A,250V,5SEC	71400	MDX-2
	-----			(220V OPTION. STANDARD ONLY)		
F2	159-0023-00	XB017630		FUSE,CARTRIDGE:3AG,2A,250V,5SEC	71400	MDX-2
	-----			(120V OPERATION. OPTION 2 ONLY)		
F2	159-0027-00			FUSE,CARTRIDGE:3AG,4A,125V,SLOW-BLOW	71400	MDX4
	-----			(120V OPERATION)		
F20	159-0126-00			FUSE,CARTRIDGE:3AG,2.5A,250V,0.65 SEC	71400	AGC2-1/2
F22	159-0126-00			FUSE,CARTRIDGE:3AG,2.5A,250V,0.65 SEC	71400	AGC2-1/2
F35	159-0096-00			FUSE,CARTRIDGE:3AG,7.5A,32V,0.5 SEC	71400	AGC 7 1/2
F50	159-0006-00			FUSE,CARTRIDGE:5A,3AG,125V,SLOW-BLOW	71400	MDX5
J10	131-1078-00			CONNECTOR,RCPT,:28/56 CONTACT	95238	600-1156Y256DF30



Replaceable Electrical Parts—TM 506/RTM 506

Ckt No.	Tektronix Part No.	Serial/Model No. Eff	Dscont	Name & Description	Mfr Code	Mfr Part Number
J20	131-1078-00			CONNECTOR, RCPT, :28/56 CONTACT	95238	600-1156Y256DF30
J30	131-1078-00			CONNECTOR, RCPT, :28/56 CONTACT	95238	600-1156Y256DF30
J40	131-1078-00			CONNECTOR, RCPT, :28/56 CONTACT	95238	600-1156Y256DF30
J50	131-1078-00			CONNECTOR, RCPT, :28/56 CONTACT	95238	600-1156Y256DF30
J60	131-1078-00			CONNECTOR, RCPT, :28/56 CONTACT	95238	600-1156Y256DF30
Q10	151-0373-00			TRANSISTOR: SILICON, PNP	80009	151-0373-00
Q12	151-0436-00			TRANSISTOR: SILICON, NPN	80009	151-0436-00
Q20	151-0373-00			TRANSISTOR: SILICON, PNP	80009	151-0373-00
Q22	151-0436-00			TRANSISTOR: SILICON, NPN	80009	151-0436-00
Q30	151-0373-00			TRANSISTOR: SILICON, PNP	80009	151-0373-00
Q32	151-0436-00			TRANSISTOR: SILICON, NPN	80009	151-0436-00
Q40	151-0373-00			TRANSISTOR: SILICON, PNP	80009	151-0373-00
Q42	151-0436-00			TRANSISTOR: SILICON, NPN	80009	151-0436-00
Q50	151-0373-00			TRANSISTOR: SILICON, PNP	80009	151-0373-00
Q52	151-0436-00			TRANSISTOR: SILICON, NPN	80009	151-0436-00
Q60	151-0258-00			TRANSISTOR: SILICON, PNP	04713	MJ2955
Q62	151-0140-00			TRANSISTOR: SILICON, NPN	80009	151-0140-00
R2	308-0704-00			RES., FXD, WW: 8.8 OHM, 5%, 5W	91637	CW5-8R800J
R20	306-0102-00			RES., FXD, CMPSN: 1K OHM, 10%, 2W	01121	HB1021
R22	306-0102-00			RES., FXD, CMPSN: 1K OHM, 10%, 2W	01121	HB1021
R30	303-0102-00			RES., FXD, CMPSN: 1K OHM, 5%, 1W	01121	GB1025
R35	303-0511-00			RES., FXD, CMPSN: 510 OHM, 5%, 1W	01121	GB5115
R50	303-0511-00			RES., FXD, CMPSN: 510 OHM, 5%, 1W	01121	GB5115
S2	260-1222-00			SWITCH, PUSH-PUL: 10A, 250VAC	91929	2DM301
S3	260-0551-00			SW, THERMOSTATIC: NC, 10A, 240VAC	73803	20700L63-327
S4	260-0551-00			SW, THERMOSTATIC: NC, 10A, 240VAC	73803	20700L63-327
T1	120-0967-00 -----	B010100	B018339	XFMR, PWR, STPDN: (STANDARD ONLY)	80009	120-0967-00
T1	120-0967-01 -----	B018340		XFMR, PWR, STPDN: (STANDARD ONLY)	80009	120-0967-01
T1	120-0967-00 -----	B010100	B018389	XFMR, PWR, STPDN: (OPTION 2 ONLY)	80009	120-0967-00
T1	120-0967-01 -----	B018390		XFMR, PWR, STPDN: (OPTION 2 ONLY)	80009	120-0967-01

# DIAGRAMS AND CIRCUIT BOARD ILLUSTRATIONS

## Symbols

Graphic symbols and class designation letters are based on ANSI Standard Y32.2-1975.

Logic symbology is based on ANSI Y32.14-1973 in terms of positive logic. Logic symbols depict the logic function performed and may differ from the manufacturer's data.

The overline on a signal name indicates that the signal performs its intended function when it is in the low state.

Abbreviations are based on ANSI Y1.1-1972.

Other ANSI standards that are used in the preparation of diagrams by Tektronix, Inc. are:

- Y14.15, 1966 Drafting Practices.
- Y14.2, 1973 Line Conventions and Lettering.
- Y10.5, 1968 Letter Symbols for Quantities Used in Electrical Science and Electrical Engineering.

American National Standard Institute  
1430 Broadway  
New York, New York 10018

## Component Values

Electrical components shown on the diagrams are in the following units unless noted otherwise:

- Capacitors = Values one or greater are in picofarads (pF). Values less than one are in microfarads ( $\mu$ F).
- Resistors = Ohms ( $\Omega$ ).

———— The information and special symbols below may appear in this manual. ————

## Assembly Numbers and Grid Coordinates

Each assembly in the instrument is assigned an assembly number (e.g., A20). The assembly number appears on the circuit board outline on the diagram, in the title for the circuit board component location illustration, and in the lookup table for the schematic diagram and corresponding component locator illustration. The Replaceable Electrical Parts list is arranged by assemblies in numerical sequence; the components are listed by component number \*(see following illustration for constructing a component number).

The schematic diagram and circuit board component location illustration have grids. A lookup table with the grid coordinates is provided for ease of locating the component. Only the components illustrated on the facing diagram are listed in the lookup table. When more than one schematic diagram is used to illustrate the circuitry on a circuit board, the circuit board illustration may only appear opposite the first diagram on which it was illustrated; the lookup table will list the diagram number of other diagrams that the circuitry of the circuit board appears on.

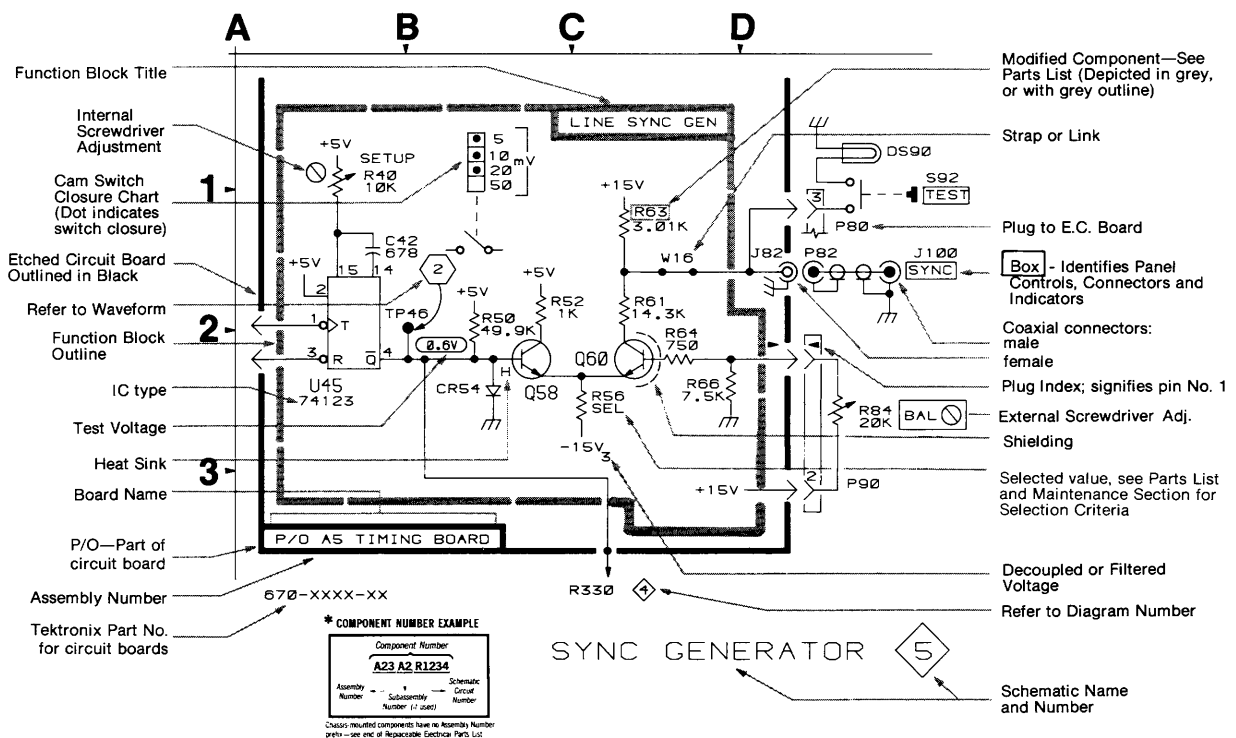

# POWER MODULE INTERFACE PIN ASSIGNMENTS

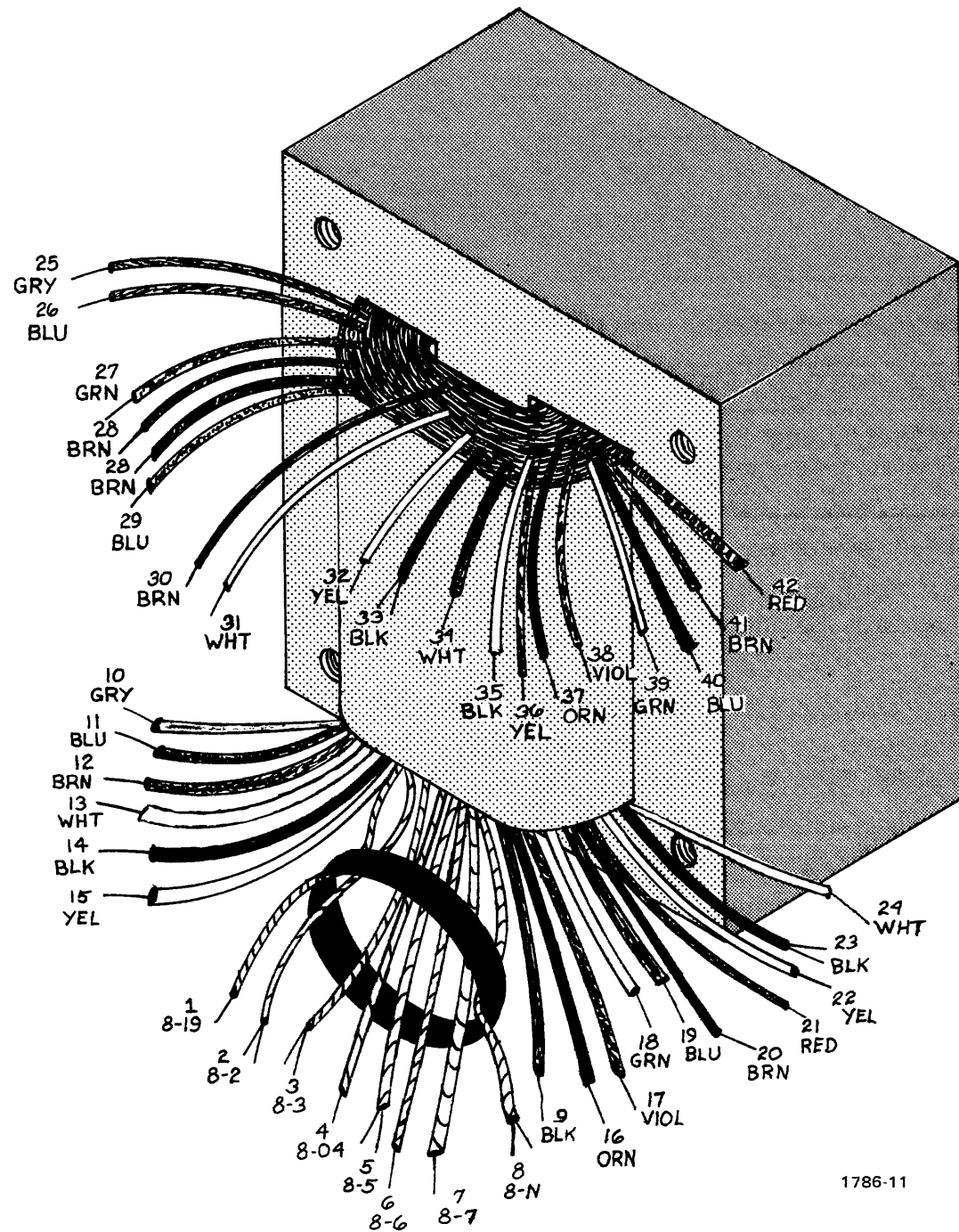

Transformer wire colors.

1786-11

No permanent I/O assignments. Refer to plug-in module manuals for specific assignments.

- 25 Vac winding.
- +33.5 V filter
- Base lead of PNP Series-Pass.
- Emitter lead of PNP Series-Pass.
- ±33.5 V common return.
- 33.5 V filtered dc.
- Emitter lead of NPN Series-Pass.
- Base lead of NPN Series-Pass.
- 17.5 Vac winding.
- +11.5 V common return.
- +11.5 V common return.
- +11.5 V filtered dc.
- 25 Vac winding.

A	B
28	28
27	27
26	26
25	25
24	24
23	23
22	22
21	21
20	20
19	19
18	18
17	17
16	16
15	15
14	14
13	13
12	12
11	11
10	10
9	9
8	8
7	7
6	6
5	5
4	4
3	3
2	2
1	1
A	B

No permanent I/O assignments. Refer to plug-in module manuals for specific assignments.

- 25 Vac winding.
- +33.5 V filtered dc.
- Collector lead of PNP Series-Pass.
- Transformer shield lead.
- ±33.5 V common return.
- 33.5 V filtered dc.
- Collector lead of NPN Series-Pass.
- No connection.
- 17.5 Vac winding.
- +11.5 V common return.
- +11.5 V common return.
- +11.5 V filtered dc.
- 25 Vac winding.

1786-12

P  
Transfo  
power at  
S3, S4,  
selector  
S3 and  
mounted  
which in  
power  
temperal  
safe level  
strument  
will clos  
the prin  
shunts li  
the neutr  
P1 is wi  
primary  
parallel f  
line volta  
is wirec  
primary  
for 220  
voltage c

120

## POWER MODULE INTERFACE PIN ASSIGNMENTS

	A	B	
	28	28	
	27	27	
	26	26	
	25	25	
	24	24	
	23	23	
No permanent I/O assignments. Refer to plug-in module manuals for specific assignments.	22	22	No permanent I/O assignments. Refer to plug-in module manuals for specific assignments.
	21	21	
	20	20	
	19	19	
	18	18	
	17	17	
	16	16	
	15	15	
	14	14	
25 Vac winding.	13	13	25 Vac winding.
+33.5 V filter	12	12	+33.5 V filtered dc.
Base lead of PNP Series-Pass.	11	11	Collector lead of PNP Series-Pass.
Emitter lead of PNP Series-Pass.	10	10	Transformer shield lead.
±33.5 V common return.	9	9	±33.5 V common return.
-33.5 V filtered dc.	8	8	-33.5 V filtered dc.
Emitter lead of NPN Series-Pass.	7	7	Collector lead of NPN Series-Pass.
Base lead of NPN Series-Pass.	6	6	No connection.
17.5 Vac winding.	5	5	17.5 Vac winding.
+11.5 V common return.	4	4	+11.5 V common return.
+11.5 V common return.	3	3	+11.5 V common return.
+11.5 V filtered dc.	2	2	+11.5 V filtered dc.
25 Vac winding.	1	1	25 Vac winding.
	A	B	

1786-12

## DETAILED BLOCK DIAGRAM

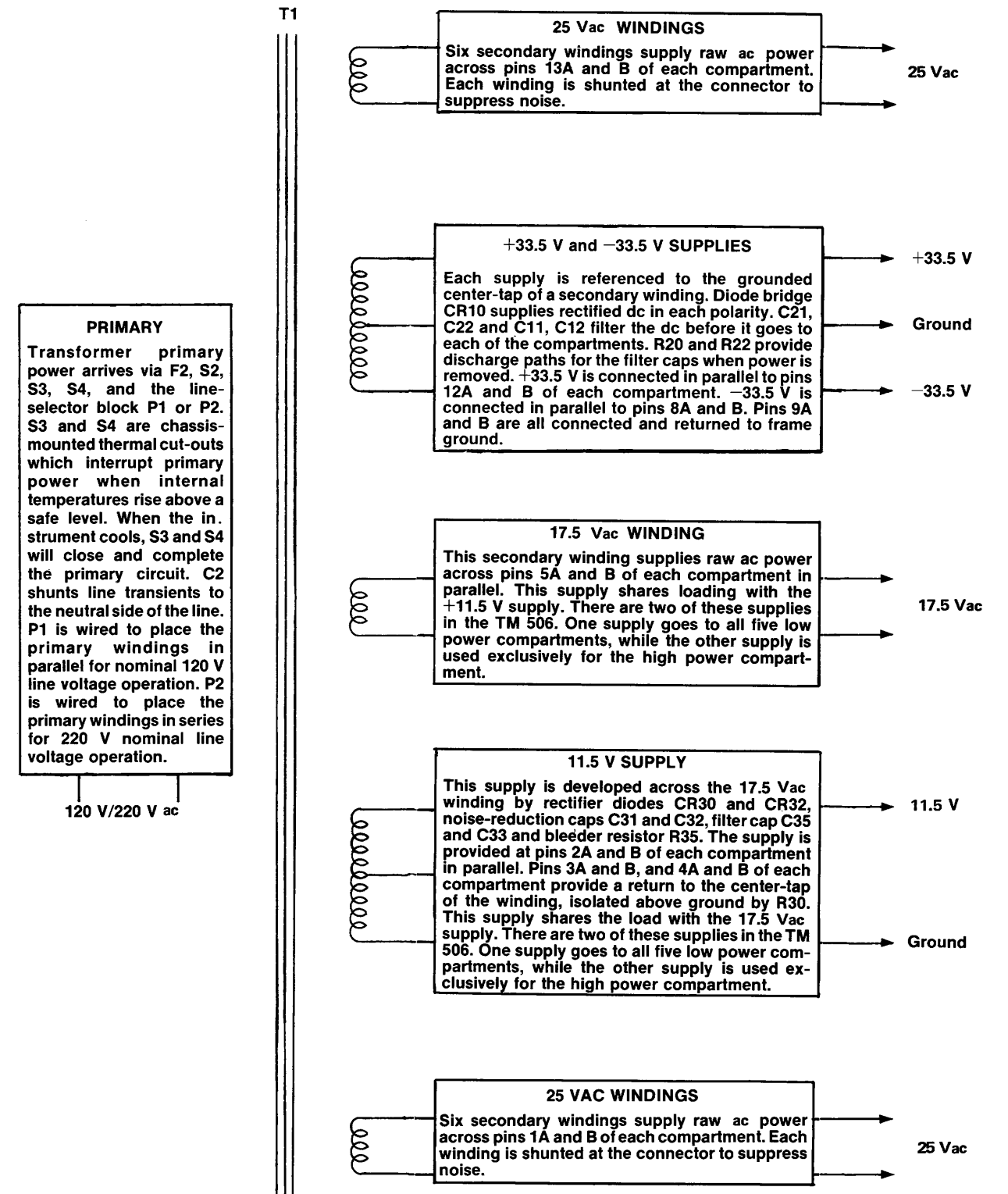

1786-13

BLOCK DIAGRAM

# PARTS LOCATION GRID

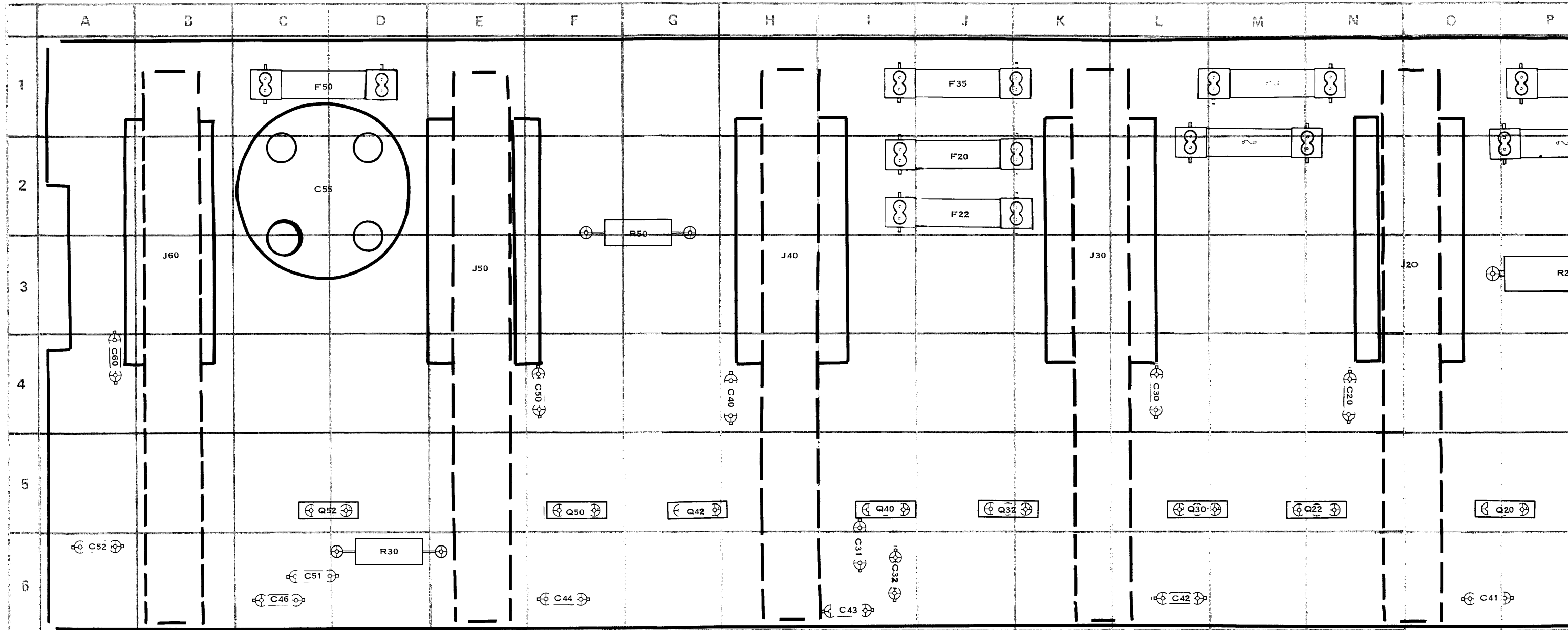

CKT NO	GRID LOC	CKT NO	GRID LOC	CKT NO	GRID LOC
C2	S3	F20	J2	Q40	I5
C10	Q4	F22	J2	Q42	G5
C20	N4	F35	J7	Q50	F5
C30	L4	F50	C7	Q52	C5
C31	I6				
C32	I6	J10	R3	R2	P3
C39	Q6	J20	O3	R30	D6
C40	H4	J30	K3	R50	G2
C41	O6	J40	H3		
C42	L6	J50	E3		
C43	I6	J60	B3		
C44	F6				
C46	C6	Q10	S5		
C50	F4	Q12	Q5		
C51	C6	Q20	P5		
C52	A6	Q22	N5		
C55	C2	Q30	L5		
C60	A4	Q32	J5		

# PARTS LOCATION GRID

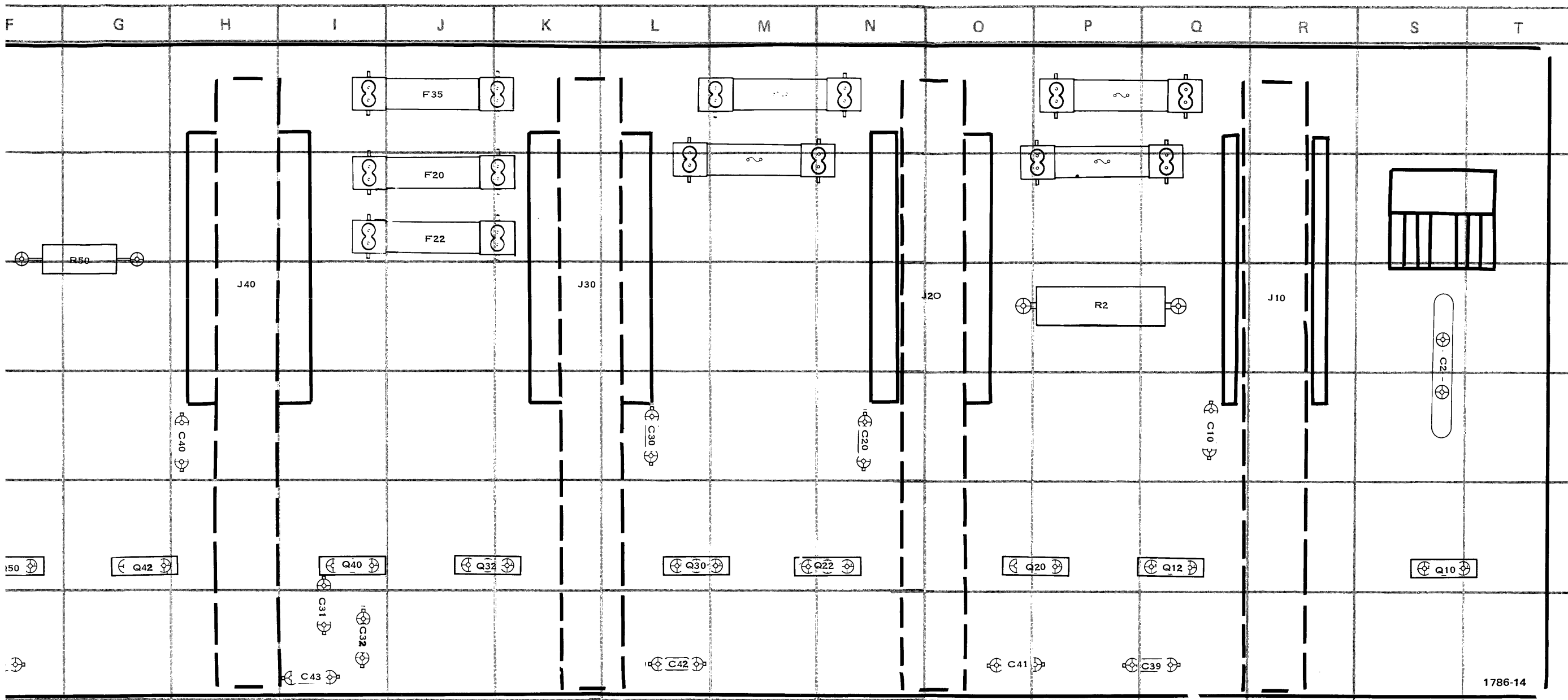

# PARTS LOCATION GRID

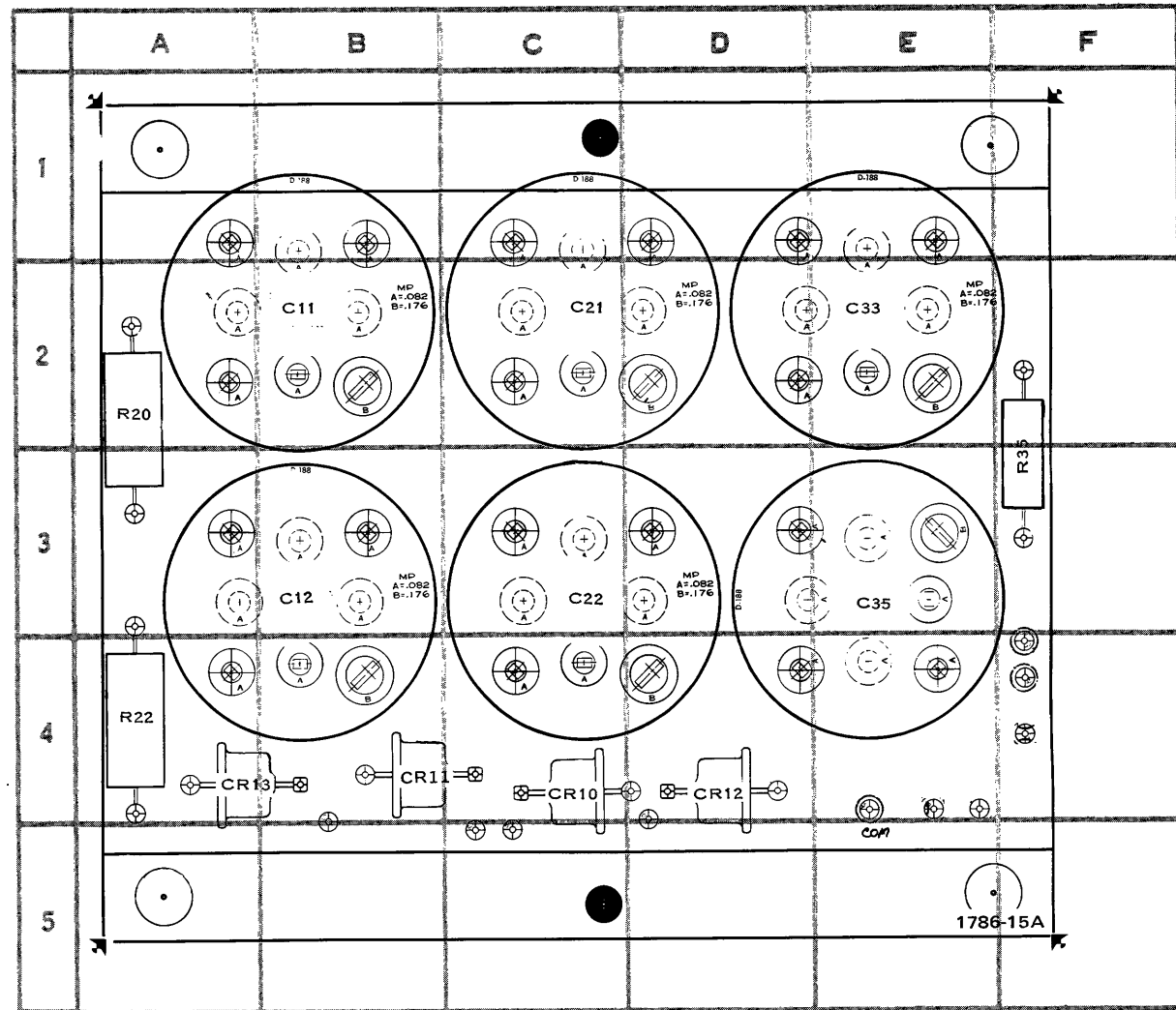

CKT NO	GRID LOC
C11	B2
C12	B3
C21	C2
C22	C3
C33	E2
C35	E3
CR10	C4
CR11	B4
CR12	D4
CR13	A4
R20	A2
R22	A4
R35	R3

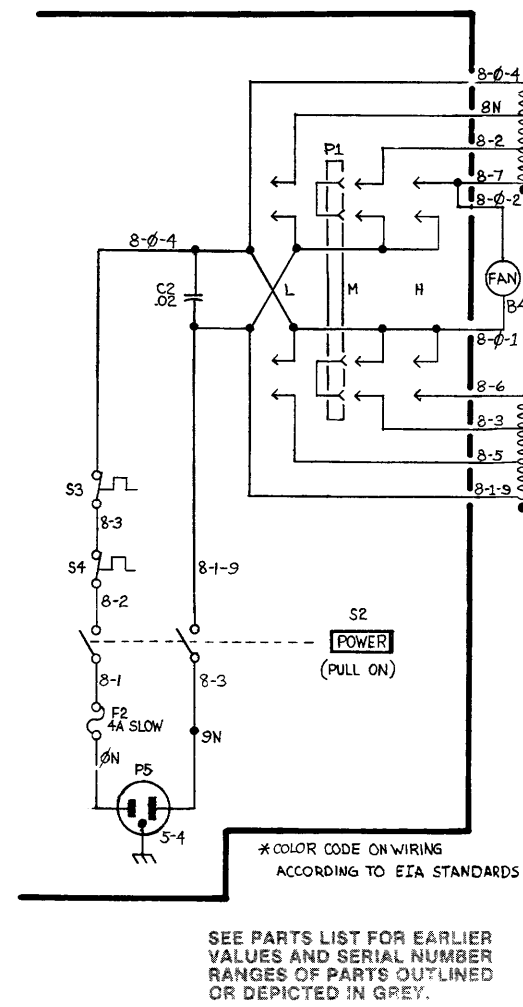

TM 506/RTM 506

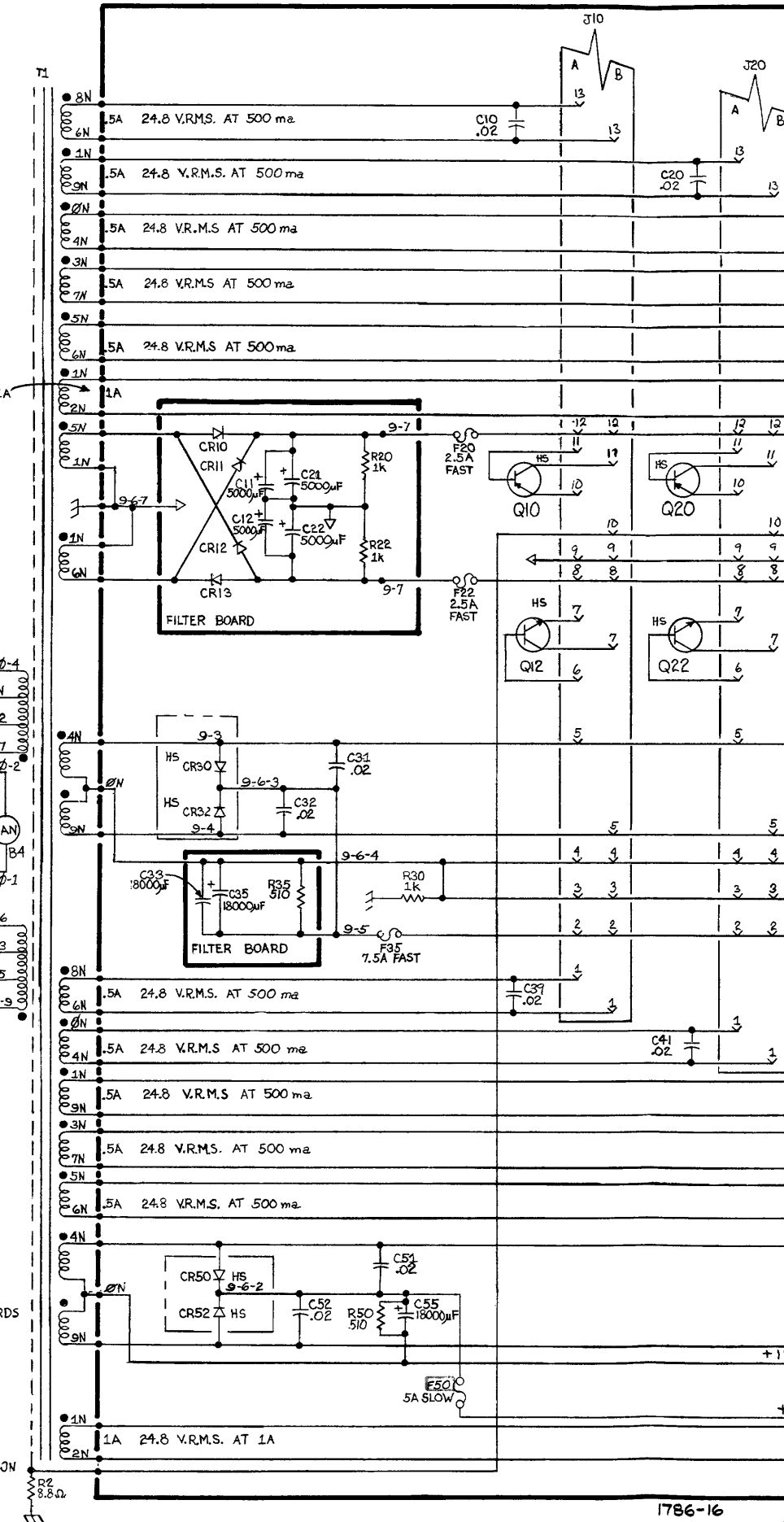

1786-16  
REV C JUNE 19

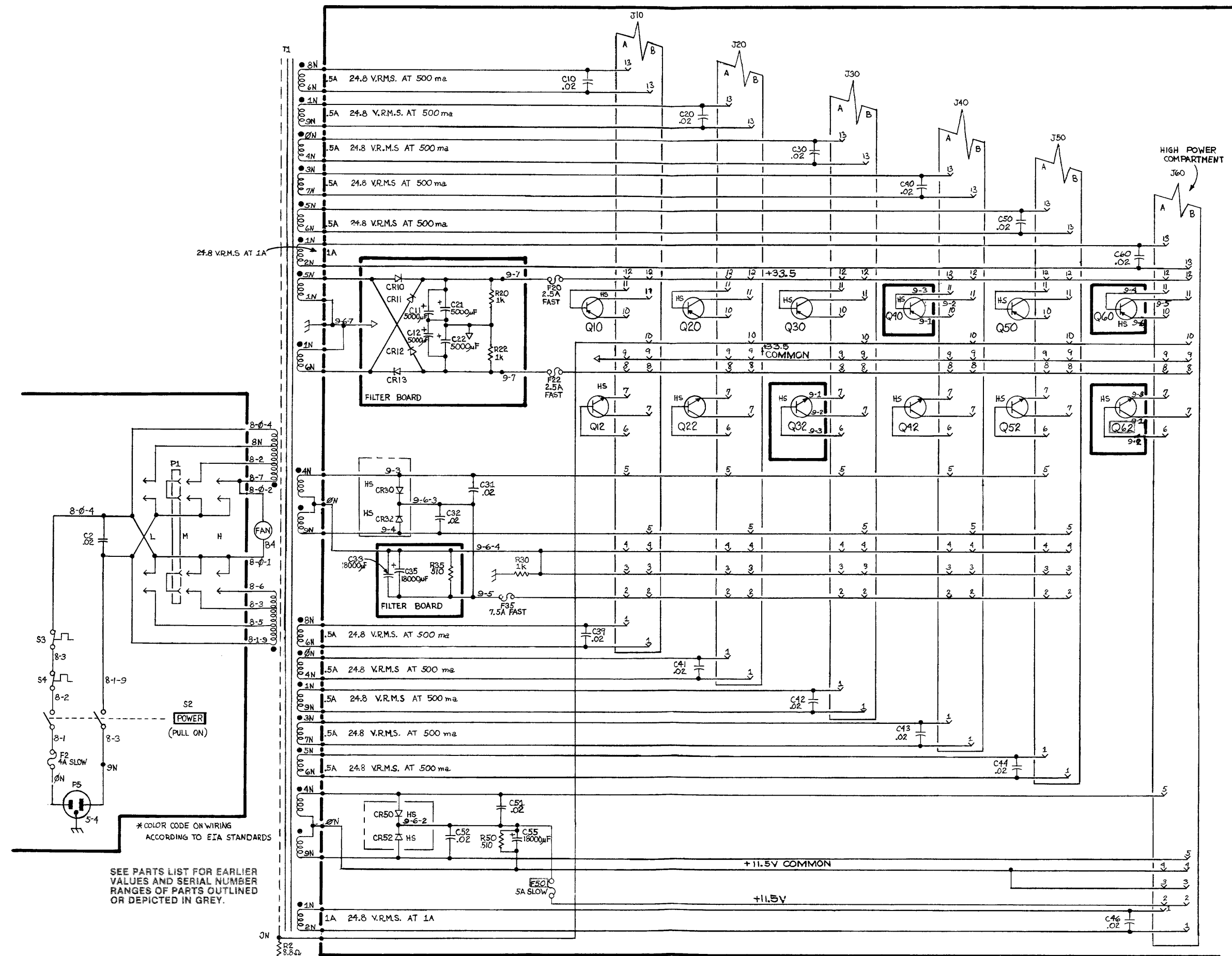
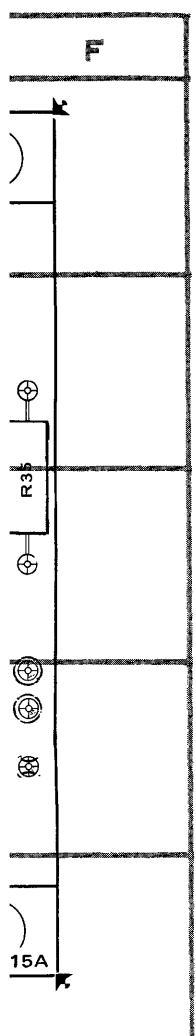

SEE PARTS LIST FOR EARLIER VALUES AND SERIAL NUMBER RANGES OF PARTS OUTLINED OR DEPICTED IN GREY.

\* COLOR CODE ON WIRING ACCORDING TO EIA STANDARDS



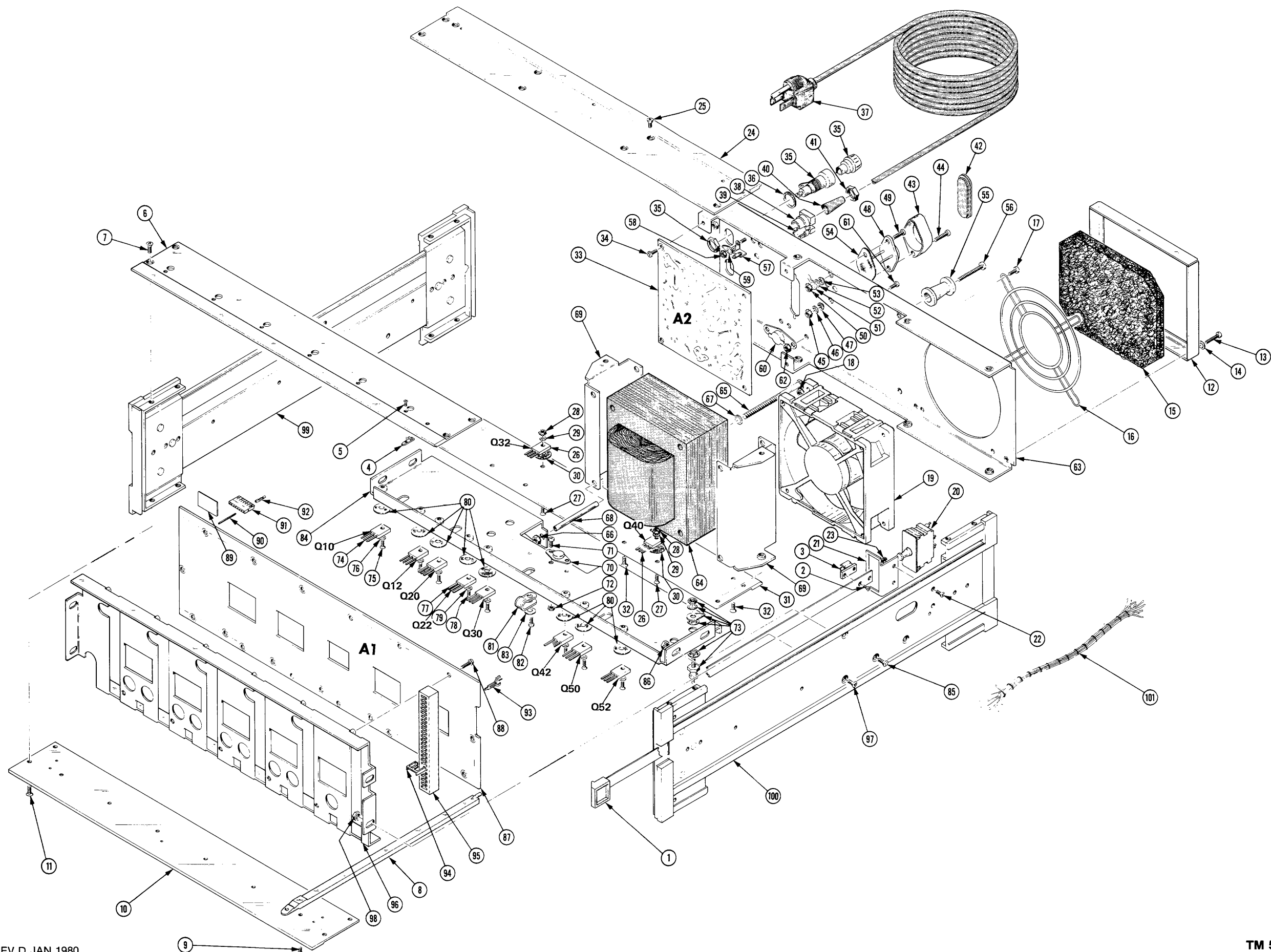

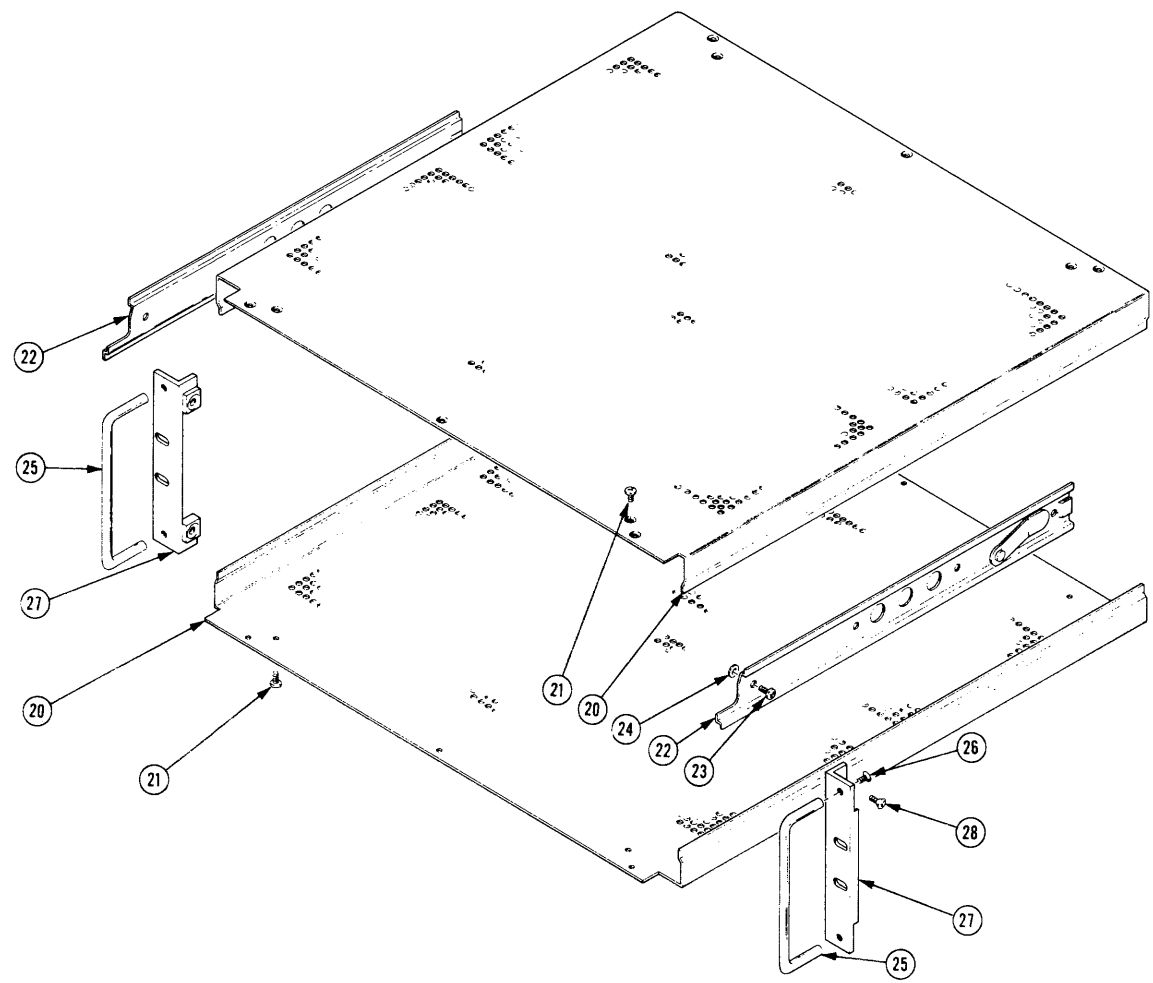
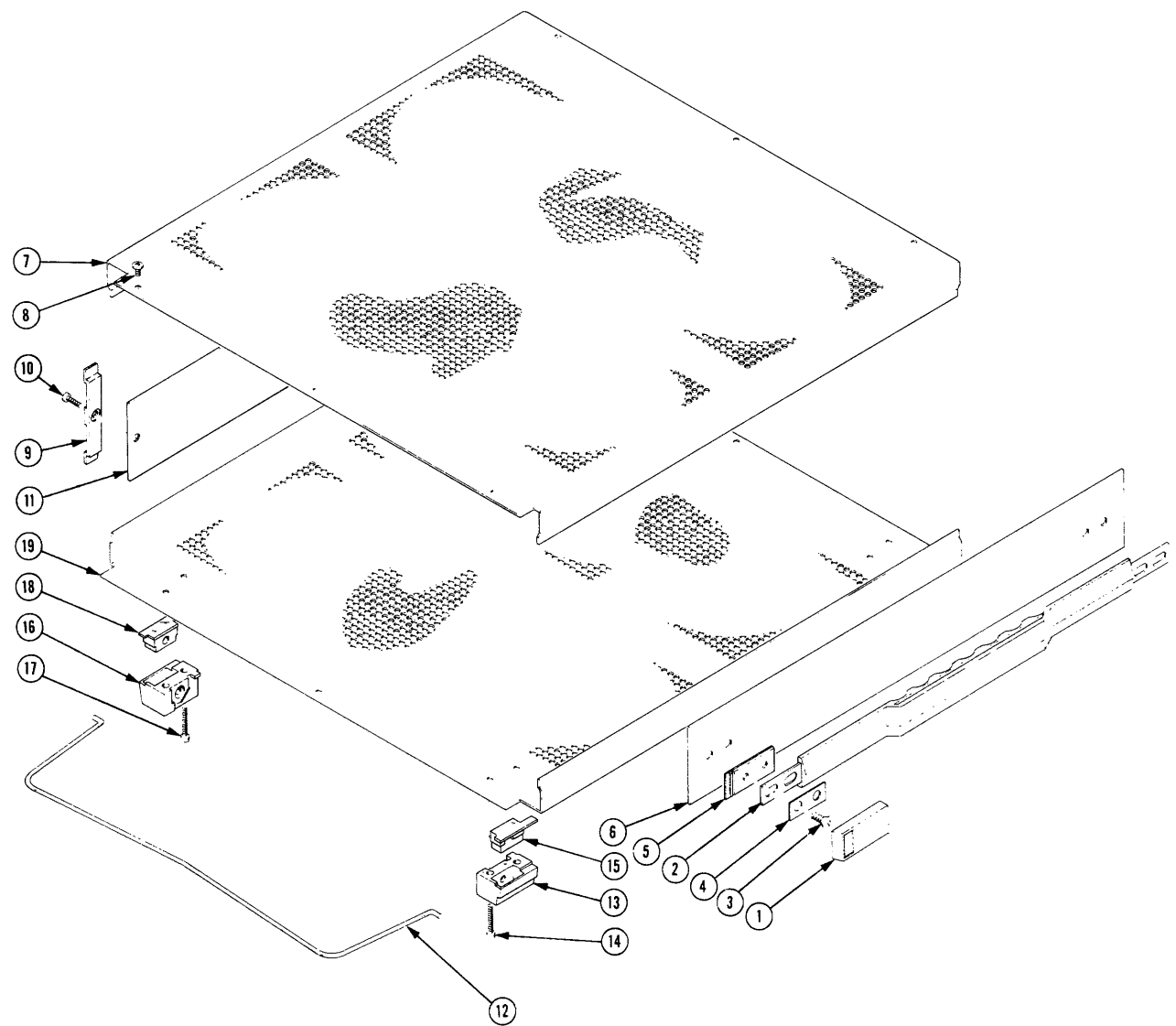

# REPLACEABLE MECHANICAL PARTS

## PARTS ORDERING INFORMATION

Replacement parts are available from or through your local Tektronix, Inc. Field Office or representative.

Changes to Tektronix instruments are sometimes made to accommodate improved components as they become available, and to give you the benefit of the latest circuit improvements developed in our engineering department. It is therefore important, when ordering parts, to include the following information in your order: Part number, instrument type or number, serial number, and modification number if applicable.

If a part you have ordered has been replaced with a new or improved part, your local Tektronix, Inc. Field Office or representative will contact you concerning any change in part number.

Change information, if any, is located at the rear of this manual.

## SPECIAL NOTES AND SYMBOLS

X000	Part first added at this serial number
00X	Part removed after this serial number

## FIGURE AND INDEX NUMBERS

Items in this section are referenced by figure and index numbers to the illustrations.

## INDENTATION SYSTEM

This mechanical parts list is indented to indicate item relationships. Following is an example of the indentation system used in the description column.

1	2	3	4	5	Name & Description
					<i>Assembly and/or Component</i>
					<i>Attaching parts for Assembly and/or Component</i>
					--- * ---
					<i>Detail Part of Assembly and/or Component</i>
					<i>Attaching parts for Detail Part</i>
					--- * ---
					<i>Parts of Detail Part</i>
					<i>Attaching parts for Parts of Detail Part</i>
					--- * ---

Attaching Parts always appear in the same indentation as the item it mounts, while the detail parts are indented to the right. Indented items are part of, and included with, the next higher indentation. The separation symbol --- \* --- indicates the end of attaching parts.

**Attaching parts must be purchased separately, unless otherwise specified.**

## ITEM NAME

In the Parts List, an Item Name is separated from the description by a colon (:). Because of space limitations, an Item Name may sometimes appear as incomplete. For further Item Name identification, the U.S. Federal Cataloging Handbook H6-1 can be utilized where possible.

## ABBREVIATIONS

..	INCH	ELCTRN	ELECTRON	IN	INCH	SE	SINGLE END
#	NUMBER SIZE	ELEC	ELECTRICAL	INCAND	INCANDESCENT	SECT	SECTION
ACTR	ACTUATOR	ELCTLT	ELECTROLYTIC	INSUL	INSULATOR	SEMICON	SEMICONDUCTOR
ADPTR	ADAPTER	ELEM	ELEMENT	INTL	INTERNAL	SHLD	SHIELD
ALIGN	ALIGNMENT	EPL	ELECTRICAL PARTS LIST	LPHLDR	LAMPHOLDER	SHLDR	SHOULDERED
AL	ALUMINUM	EQPT	EQUIPMENT	MACH	MACHINE	SKT	SOCKET
ASSEM	ASSEMBLED	EXT	EXTERNAL	MECH	MECHANICAL	SL	SLIDE
ASSY	ASSEMBLY	FIL	FILLISTER HEAD	MTG	MOUNTING	SLFLKG	SELF-LOCKING
ATTEN	ATTENUATOR	FLEX	FLEXIBLE	NIP	NIPPLE	SLVG	SLEEVING
AWG	AMERICAN WIRE GAGE	FLH	FLAT HEAD	NON WIRE	NOT WIRE WOUND	SPR	SPRING
BD	BOARD	FLTR	FILTER	OB	ORDER BY DESCRIPTION	SQ	SQUARE
BRKT	BRACKET	FR	FRAME or FRONT	OD	OUTSIDE DIAMETER	SST	STAINLESS STEEL
BRS	BRASS	FSTNR	FASTENER	OVH	OVAL HEAD	STL	STEEL
BRZ	BRONZE	FT	FOOT	PH BRZ	PHOSPHOR BRONZE	SW	SWITCH
BSHG	BUSHING	FXD	FIXED	PL	PLAIN or PLATE	T	TUBE
CAB	CABINET	GSKT	GASKET	PLSTC	PLASTIC	TERM	TERMINAL
CAP	CAPACITOR	HDL	HANDLE	PN	PART NUMBER	THD	THREAD
CER	CERAMIC	HEX	HEXAGON	PNH	PAN HEAD	THK	THICK
CHAS	CHASSIS	HEX HD	HEXAGONAL HEAD	PWR	POWER	TNSN	TENSION
CKT	CIRCUIT	HEX SOC	HEXAGONAL SOCKET	RCPT	RECEPTACLE	TPG	TAPPING
COMP	COMPOSITION	HLCPS	HELICAL COMPRESSION	RES	RESISTOR	TRH	TRUSS HEAD
CONN	CONNECTOR	HLEXT	HELICAL EXTENSION	RGD	RIGID	V	VOLTAGE
COV	COVER	HV	HIGH VOLTAGE	RLF	RELIEF	VAR	VARIABLE
CPLG	COUPLING	IC	INTEGRATED CIRCUIT	RTNR	RETAINER	W/	WITH
CRT	CATHODE RAY TUBE	ID	INSIDE DIAMETER	SCH	SOCKET HEAD	WSHR	WASHER
DEG	DEGREE	IDENT	IDENTIFICATION	SCOPE	OSCILLOSCOPE	XFMR	TRANSFORMER
DWR	DRAWER	IMPLR	IMPELLER	SCR	SCREW	XSTR	TRANSISTOR

CROSS INDEX—MFR. CODE NUMBER TO MANUFACTURER

Mfr. Code	Manufacturer	Address	City, State, Zip
04713	MOTOROLA, INC., SEMICONDUCTOR PROD. DIV.	5005 E MCDOWELL RD, PO BOX 20923	PHOENIX, AZ 85036
06540	AMATOM ELECTRONIC HARDWARE, DIV. OF MITE CORP.	446 BLAKE ST.	NEW HAVEN, CT 06515
06666	GENERAL DEVICES CO., INC.	525 S. WEBSTER AVE.	INDIANAPOLIS, IN 46219
11897	PLASTIGLIDE MFG. CORPORATION	P O BOX 867, 1757 STANFORD ST.	SANTA MONICA, CA 90406
12136	PHILADELPHIA HANDLE COMPANY, INC.	1643 HADDON AVENUE	CAMDEN, NJ 08103
12327	FREEWAY CORPORATION	9301 ALLEN DRIVE	CLEVELAND, OH 44125
12360	ALBANY PRODUCTS CO., DIV. OF PNEUMO DYNAMICS CORPORATION	145 WOODWARD AVENUE	SOUTH NORWALK, CT 06586
13511	AMPHENOL CARDRE DIV., BUNKER RAMO CORP.		LOS GATOS, CA 95030
16428	BELDEN CORP.	P. O. BOX 1331	RICHMOND, IN 47374
22526	BERG ELECTRONICS, INC.	YOUK EXPRESSWAY	NEW CUMBERLAND, PA 17070
70485	ATLANTIC INDIA RUBBER WORKS, INC.	571 W. POLK ST.	CHICAGO, IL 60607
71468	ITT CANNON ELECTRIC	666 E. DYER RD.	SANTA ANA, CA 92702
71785	TRW, CINCH CONNECTORS	1501 MORSE AVENUE	ELK GROVE VILLAGE, IL 60007
73743	FISCHER SPECIAL MFG. CO.	446 MORGAN ST.	CINCINNATI, OH 45206
73803	TEXAS INSTRUMENTS, INC., METALLURGICAL MATERIALS DIV.	34 FOREST STREET	ATTLEBORO, MA 02703
74921	ITEN FIBRE CO.,	4001 BENEFIT AVE., P O BOX 9	ASHTABULA, OH 44004
75915	LITTELFUSE, INC.	800 E. NORTHWEST HWY	DES PLAINES, IL 60016
76689	NATIONAL SCREW AND MFG. CO.	100 WILSHIRE BLVD., SUITE 315	SANTA MONICA, CA 90401
78189	ILLINOIS TOOL WORKS, INC. SHAKEPROOF DIVISION	ST. CHARLES ROAD	ELGIN, IL 60120
80009	TEKTRONIX, INC.	P O BOX 500	BEAVERTON, OR 97077
82877	ROTRON, INC.	7-9 HASBROUCK LANE	WOODSTOCK, NY 12498
83385	CENTRAL SCREW CO.	2530 CRESCENT DR.	BROADVIEW, IL 60153
86928	SEASTROM MFG. COMPANY, INC.	701 SONORA AVENUE	GLENDALE, CA 91201
91929	HONEYWELL, INC., MICRO SWITCH DIV.	CHICAGO & SPRING STS.	FREEPORT, IL 61032
93907	CAMCAR SCREW AND MFG. CO.	600 18TH AVE.	ROCKFORD, IL 61101
95238	CONTINENTAL CONNECTOR CORP.	34-63 56TH ST.	WOODSIDE, NY 11377
95987	WECKESSER CO., INC.	4444 WEST IRVING PARK RD.	CHICAGO, IL 60641

Fig. & Index No.	Tektronix Part No.	Serial/Model No. Eff	Dscont	Qty	1	2	3	4	5	Name & Description	Mfr Code	Mfr Part Number
1-1	384-1243-00			1						EXTENSION SHAFT:POWER SWITCH (ATTACHING PARTS)	80009	384-1243-00
-2	211-0105-00	B010100	B018789	2						SCREW,MACHINE:4-40 X 0.188"100 DEG,FLH STL	83385	OBD
	213-0815-00	B018790		2						SCREW,TPG,TR:4-20,0.188L,PLASTITE - - - * - - -	93907	OBD
-3	214-2010-00			1						ACTUATOR,SWITCH:POWER	80009	214-2010-00
-4	351-0379-01			6						GUIDE,PL-IN:UPPER (ATTACHING PARTS)	80009	351-0379-01
-5	211-0030-00			6						SCREW,MACHINE:2-56 X 0.25"82 DEG,FLH STL - - - * - - -	83385	OBD
-6	426-1120-00			1						FRAME SECT,CAB.:UPPER FRONT (ATTACHING PARTS)	80009	426-1120-00
-7	212-0040-00			4						SCREW,MACHINE:8-32 X 0.375 100 DEG,FLH STL - - - * - - -	83385	OBD
-8	351-0286-04	B010100	B018789	6						GUIDE,PL-IN UNI:LOWER,BLACK NYLON	80009	351-0286-04
	351-0286-07	B018790	B029999	6						GUIDE,PL-IN UNI:LOWER,NYLON	80009	351-0286-07
	351-0286-08	B030000		6						GUIDE,PL-IN UNI:LOWER,NYLON (ATTACHING PARTS)	80009	351-0286-08
-9	211-0101-00	B010100	B018789	6						SCREW,MACHINE:4-40 X 0.25" 100 DEG,FLH STL	83385	OBD
	213-0813-00	B018790		6						SCREW,TPG,TR:4-20,0.312 L,PLASTITE - - - * - - -	93907	OBD
	334-2380-00			1						MARKER,IDENT:MKD HIGH PWR COMPARTMENT	80009	334-2380-00
	334-3379-01	XB016460		1						MARKER,IDENT:MARKED GROUND SYMBOL	80009	334-3379-01
-10	426-1115-00			1						FRAME SECT,CAB.:LOWER FRONT (ATTACHING PARTS)	80009	426-1115-00
-11	212-0040-00			4						SCREW,MACHINE:8-32 X 0.375 100 DEG,FLH STL - - - * - - -	83385	OBD
-12	200-0541-00			1						RTNR,AIR FILTER:0.594 X 4.562X 5.625,AL (ATTACHING PARTS)	80009	200-0541-00
-13	212-0033-00			4						SCREW,MACHINE:8-32 X 0.750 INCH,PNH STL	83385	OBD
-14	210-0804-00			4						WASHER,FLAT:0.17 ID X 0.375 INCH OD,STL - - - * - - -	12327	OBD
-15	378-0029-00			1						FIL ELEM,AIR CO:FOAM	80009	378-0029-00
-16	214-0762-00			1						GRILLE,METAL:ZINC PLATED STL (ATTACHING PARTS)	82877	20132-2
-17	211-0511-00			4						SCREW,MACHINE:6-32 X 0.500,PNH,STL,CD PL	83385	OBD
-18	210-0457-00			4						NUT,PL,ASSEM WA:6-32 X 0.312 INCH,STL - - - * - - -	83385	OBD
-19	119-0026-00			1						FAN,AXIAL:1.500 X 4.750 INCH,WHISPER	82877	WR2A1
-20	260-1222-00			1						SWITCH,PUSH-PUL:10A,250VAC	91929	2DM301
-21	407-0895-00	B010100	B011519	1						BRACKET,ELEC SW:ALUMINUM	80009	407-0895-00
	407-0895-01	B011520		1						BRACKET,ELEC SW:ALUMINUM (ATTACHING PARTS)	80009	407-0895-01
-22	211-0038-00			2						SCREW,MACHINE:4-40 X 0.312,FLH,100 DEG	83385	OBD
-23	210-0586-00			2						NUT,PL,ASSEM WA:4-40 X 0.25,STL CD PL - - - * - - -	83385	211-041800-00
-24	426-1121-00			1						FRAME SECT,CAB.:UPPER REAR (ATTACHING PARTS)	80009	426-1121-00
-25	212-0040-00			10						SCREW,MACHINE:8-32 X 0.375 100 DEG,FLH STL - - - * - - -	83385	OBD
-26	-----			2						TRANSISTOR:(SEE Q32,Q40 EPL) (ATTACHING PARTS)		
-27	211-0114-00			2						SCREW,MACHINE:4-40 X 0.438 INCH,FLH STL	83385	OBD
-28	210-0586-00			2						NUT,PL,ASSEM WA:4-40 X 0.25,STL CD PL	83385	211-041800-00
-29	210-1122-00			2						WASHER,LOCK:0.228 ID X 0.375 INCH OD,STL - - - * - - -	04713	B52200F006
-30	342-0136-00			2						INSULATOR,WSHR:0.812 OD X 0.0025 INCH THK	04713	OBD
-31	426-1116-00			1						FRAME SECT,CAB.:LOWER RIGHT (ATTACHING PARTS)	80009	426-1116-00
-32	212-0040-00			10						SCREW,MACHINE:8-32 X 0.375 100 DEG,FLH STL - - - * - - -	83385	OBD
-33	-----			1						CKT BOARD ASSY:FILTER(SEE A2 EPL) (ATTACHING PARTS)		
-34	211-0507-00			4						SCREW,MACHINE:6-32 X 0.312 INCH,PNH STL - - - * - - -	83385	OBD

Replaceable Mechanical Parts--TM 506/RTM 506

Fig. & Index No.	Tektronix Part No.	Serial/Model No. Eff	Dscont	Qty	1 2 3 4 5	Name & Description	Mfr Code	Mfr Part Number
1-35	352-0362-00			1		FUSEHOLDER: W/MOUNTING HARDWARE (ATTACHING PARTS)	75915	345001
-36	210-0873-00			1		WASHER, NONMETAL: 0.5 ID X 0.688 INCH OD, NPRN - - - * - - -	70485	OBD
-37	161-0033-04			1		CABLE ASSY, PWR:	16428	KH854-2
-38	358-0515-00			1		BSHG, STRAIN RLF: TOP	80009	358-0515-00
-39	358-0516-00			1		BSHG, STRAIN RLF: BOTTOM	80009	358-0516-00
-40	200-1646-00			1		CABLE NIP, PWR: 1.500 X 0.625 ID W/FLANGE	80009	200-1646-00
-41	214-2038-00			1		IND., LINE VOLTS:	80009	214-2038-00
-42	200-1814-00			1		COVER, CONN HOLE: 2.1 L X 0.8 W, PLASTIC	80009	200-1814-00
-43	200-0692-00			2		COV, TRANSISTOR: BLACK PLASTIC (ATTACHING PARTS)	80009	200-0692-00
-44	211-0513-00			2		SCREW, MACHINE: 6-32 X 0.625 INCH, PNH STL	83385	OBD
-45	210-0457-00			2		NUT, PL, ASSEM WA: 6-32 X 0.312 INCH, STL	83385	OBD
-46	210-0802-00	B010100	B010799	2		WASHER, FLAT: 0.15 ID X 0.312 INCH OD	12327	OBD
	210-0804-00	B010800		2		WASHER, FLAT: 0.17 ID X 0.375 INCH OD, STL	12327	OBD
-47	210-0935-00			2		WASHER, NONMETAL: FIBER, 0.14 ID X 0.375" OD - - - * - - -	74921	OBD
-48	-----			2		TRANSISTOR: (SEE Q60, Q62 EPL) (ATTACHING PARTS)		
-49	211-0511-00			2		SCREW, MACHINE: 6-32 X 0.500, PNH, STL, CD PL	83385	OBD
-50	210-0457-00			2		NUT, PL, ASSEM WA: 6-32 X 0.312 INCH, STL	83385	OBD
-51	210-0202-00			2		TERMINAL, LUG: 0.146 ID, LOCKING, BRZ TINNED	78189	2104-06-00-2520N
-52	210-0802-00	B010100	B010799	2		WASHER, FLAT: 0.15 ID X 0.312 INCH OD	12327	OBD
	210-0804-00	B010800		2		WASHER, FLAT: 0.17 ID X 0.375 INCH OD, STL	12327	OBD
-53	210-0935-00			2		WASHER, NONMETAL: FIBER, 0.14 ID X 0.375" OD	74921	OBD
-54	386-0978-00			2		INSULATOR, PLATE: TRANSISTOR, MICA - - - * - - -	80009	386-0978-00
-55	348-0191-00			4		LEG, ELEC EQUIP.: PLASTIC (ATTACHING PARTS)	80009	348-0191-00
-56	212-0082-00			4		SCREW, MACHINE: 8-32 X 1.250 INCH, PNH STL - - - * - - -	83385	OBD
-57	131-0022-00			1		TERMINAL CARD: SOLDER LUG/1 MTG LUG (ATTACHING PARTS)	71785	332-11-02-001
-58	210-0586-00			1		NUT, PL, ASSEM WA: 4-40 X 0.25, STL CD PL	83385	211-041800-00
-59	210-0201-00			1		TERMINAL, LUG: SE #4 - - - * - - -	86928	A373-157-2
-60	260-0551-00			1		SW, THERMOSTATIC: NC, 10A, 240VAC (ATTACHING PARTS)	73803	20700L63-327
-61	211-0504-00	B010100	B010799	2		SCREW, MACHINE: 6-32 X 0.25 INCH, PNH STL	83385	OBD
	211-0507-00	B010800		2		SCREW, MACHINE: 6-32 X 0.312 INCH, PNH STL	83385	OBD
-62	210-0457-00	B010100	B010799	2		NUT, PL, ASSEM WA: 6-32 X 0.312 INCH, STL	83385	OBD
	210-0407-00	B010800		2		NUT, PLAIN, HEX.: 6-32 X 0.25 INCH, BRZ	73743	3038-0228-402
	210-0055-00	B010800		2		WASHER, LOCK: SPLIT, 0.145 ID X 0.253 OD, STL - - - * - - -	83385	OBD
-63	333-1841-00			1		PANEL, REAR:	80009	333-1841-00
-64	-----			1		TRANSFORMER: (SEE T1 EPL) (ATTACHING PARTS)		
-65	212-0511-00			4		SCREW, MACHINE: 10-32 X 3" LONG, HEX HD STL	83385	OBD
-66	220-0410-00			4		NUT, EXTENDED WA: 10-32 X 0.375 INCH, STL	83385	OBD
-67	210-0010-00	B010100	B017519	4		WASHER, LOCK: INT, 0.20 ID X 0.376" OD, STL - (STANDARD ONLY)	78189	1210-00-00-0541C
	210-0805-00	B017520		4		WASHER, FLAT: 0.204 ID X 0.438 INCH OD, STL - (STANDARD ONLY)	12327	OBD
	210-0834-00	XB017520		4		WASHER, FLAT: 0.203 ID X 0.031 THK, NPRN - (STANDARD ONLY)	86928	A605-2-31
	210-0010-00	B010100	B017629	4		WASHER, LOCK: INT, 0.20 ID X 0.376" OD, STL - (OPTION 2 ONLY)	78189	1210-00-00-0541C
	210-0805-00	B017630		4		WASHER, FLAT: 0.204 ID X 0.438 INCH OD, STL - (OPTION 2 ONLY)	12327	OBD
	210-0834-00	XB017630		4		WASHER, FLAT: 0.203 ID X 0.031 THK, NPRN - (OPTION 2 ONLY)	86928	A605-2-31
-68	166-0434-00			4		SPACER, SLEEVE: MYLAR - - - * - - -	80009	166-0434-00

Fig. & Index No.	Tektronix Part No.	Serial/Model No. Eff Dscont	Qty	1 2 3 4 5	Name & Description	Mfr Code	Mfr Part Number
1-69	386-3002-00	B010100 B010909	2		SUPPORT, XFMR: UPPER (STANDARD ONLY)	80009	386-3002-00
	386-3002-01	B010910 B018339	2		SUPPORT, XFMR: UPPER (STANDARD ONLY)	80009	386-3002-01
	386-3002-02	B018340	2		SUPPORT, XFMR: STEEL (STANDARD ONLY)	80009	386-3002-02
	386-3002-01	B010100 B018389	2		SUPPORT, XFMR: UPPER (OPTION 2 ONLY)	80009	386-3002-01
	386-3002-02	B018390	2		SUPPORT, XFMR: STEEL (OPTION 2 ONLY)	80009	386-3002-02
-70	260-0551-00		1		SW, THERMOSTATIC: NC, 10A, 240VAC (ATTACHING PARTS)	73803	20700L63-327
-71	211-0008-00	B010100 B010799	2		SCREW, MACHINE: 4-40 X 0.25 INCH, PNH STL	83385	OBD
	211-0507-00	B010800	2		SCREW, MACHINE: 6-32 X 0.312 INCH, PNH STL	83385	OBD
-72	210-0586-00	B010100 B010799	2		NUT, PL, ASSEM WA: 4-40 X 0.25, STL CD PL	83385	211-041800-00
	210-0407-00	B010800	2		NUT, PLAIN, HEX. : 6-32 X 0.25 INCH, BRS	73743	3038-0228-402
	210-0055-00	B010800	2		WASHER, LOCK: SPLIT, 0.145 ID X 0.253 OD, STL	83385	OBD
					* - - - -		
-73	-----		4		DIODE: (SEE CR30, CR32, CR50, CR52 EPL)		
-74	-----		4		TRANSISTOR: (SEE Q10, Q20, Q30, Q50 EPL) (ATTACHING PARTS)		
-75	211-0012-00	B010100 B017029	4		SCREW, MACHINE: 4-40 X 0.375, PNH STL CD PL	83385	OBD
	211-0275-00	B017030	4		SCREW, SHOULDER: 4-40 X 0.375 L, PAN HEAD, POZ	93907	R80-20380-024
-76	210-1122-00	B010100 B017029	4		WASHER, LOCK: 0.228 ID X 0.375 INCH OD, STL	04713	B52200F006
	210-0071-00	B017030	4		WASHER, SPR TNSN: 0.146 ID X 0.323" OD, STL	78189	4706-05-01-0531
					* - - - -		
-77	-----		4		TRANSISTOR: (SEE Q12, Q22, Q42, Q52 EPL) (ATTACHING PARTS)		
-78	211-0012-00	B010100 B017029	4		SCREW, MACHINE: 4-40 X 0.375, PNH STL CD PL	83385	OBD
	211-0275-00	B017030	4		SCREW, SHOULDER: 4-40 X 0.375 L, PAN HEAD, POZ	93907	R80-20380-024
-79	210-1122-00	B010100 B017029	4		WASHER, LOCK: 0.228 ID X 0.375 INCH OD, STL	04713	B52200F006
	210-0071-00	B017030	4		WASHER, SPR TNSN: 0.146 ID X 0.323" OD, STL	78189	4706-05-01-0531
					* - - - -		
-80	342-0136-00		8		INSULATOR, WSHR: 0.812 OD X 0.0025 INCH THK	04713	OBD
-81	343-0007-00		1		CLAMP, LOOP: (ATTACHING PARTS)	95987	5-8-6B
-82	211-0097-00	B010100 B010799	1		SCREW, MACHINE: 4-40 X 0.312 INCH, PNH STL	83385	OBD
	211-0012-00	B010800	1		SCREW, MACHINE: 4-40 X 0.375, PNH STL CD PL	83385	OBD
-83	210-0851-00		1		WASHER, FLAT: 0.119 ID X 0.375 INCH OD, STL	12327	OBD
					* - - - -		
-84	214-2045-00		1		HEAT SINK, XSTR: ALUMINUM (ATTACHING PARTS)	80009	214-2045-00
-85	212-0040-00		4		SCREW, MACHINE: 8-32 X 0.375 100 DEG, FLH STL	83385	OBD
-86	210-0458-00		4		NUT, PL, ASSEM WA: 8-32 X 0.344 INCH, STL	78189	511-081800-00
					* - - - -		
-87	-----		1		CKT BOARD ASSY: INTERFACE (SEE A1 EPL) (ATTACHING PARTS)		
-88	211-0033-00		12		SCR, ASSEM WSHR: 4-40 X 0.312 PNH, STL, CD PL	83385	OBD
					* - - - -		
-89	334-2359-00		-		. CKT BOARD ASSY INCLUDES:		
			1		. MARKER, IDENT: WARNING	80009	334-2359-00
-90	131-0608-00		16		. TERMINAL, PIN: 0.365 L X 0.25 PH, BRZ, GOLD PL	22526	47357
-91	131-1895-00		1		. LINK, TERM. CONN: 8, 22 AWG, 1.5 L	80009	131-1895-00
-92	131-0707-00		6		. . CONNECTOR, TERM.: 22-26 AWG, BRS & CU BE GOLD	22526	47439
	131-1896-00		1		. LINK, TERM. CONN: 8, 22 AWG, 1.5 L	80009	131-1896-00
-93	344-0154-00	B010100 B029999	16		. CLIP, ELECTRICAL: FUSE, CKT BD MT	80009	344-0154-00
	344-0154-00	B030000	18		. CLIP, ELECTRICAL: FUSE, CKT BD MT	80009	344-0154-00
-94	214-1593-02		6		. KEY, CONN PLZN: CKT BD CONN	80009	214-1593-02
-95	131-1078-00		6		. CONNECTOR, RCPT. : 28/56 CONTACT	95238	600-1156Y256DF30
-96	441-1230-00	B010100 B029999	1		CHAS, PWR SUPPLY: INTERFACE	80009	441-1230-00
	441-1510-00	B030000	1		CHAS, PWR SUPPLY: INTERFACE (ATTACHING PARTS)	80009	441-1510-00
-97	212-0040-00		4		SCREW, MACHINE: 8-32 X 0.375 100 DEG, FLH STL	83385	OBD
					* - - - -		

**Replaceable Mechanical Parts—TM 506/RTM 506**

Fig. & Index No.	Tektronix Part No.	Serial/Model No. Eff      Dscont	Qty	1	2	3	4	5	Name & Description	Mfr Code	Mfr Part Number
	-----	-----	-	.	CHASSIS INCLUDES:						
1-	348-0509-00	XB030000	12	.	GROMMET, PLASTIC: BLACK, ROUND, 0.188 ID					80009	348-0509-00
	129-0796-00	XB030000	6	.	SPACER, POST: 0.612 L X 4-40 THRU, BRASS					80009	129-0796-00
-98	210-0458-00		4	NUT, PL, ASSEM	WA: 8-32 X 0.344 INCH, STL					78189	511-081800-00
-99	426-1122-01		1	FRAME SECT, CAB.:	LEFT					80009	426-1122-01
-100	426-1114-01		1	FRAME SECT, CAB.:	RIGHT					80009	426-1114-01
-101	179-2191-00		1	WIRING HARNESS:	CHASSIS					80009	179-2191-00



Fig. & Index No.	Tektronix Part No.	Serial/Model No. Eff	Dscont	Qty	1 2 3 4 5	Name & Description	Mfr Code	Mfr Part Number
2-1	200-0728-00			2		COV,HANDLE END:	80009	200-0728-00
-2	367-0116-00			1		HANDLE,CARRYING: (ATTACHING PARTS)	12136	OBD
-3	212-0616-00			4		SCREW,SHOULDER:10-32 X 0.531" L,HEX,STL,CD PL	80009	212-0616-00
-4	386-1624-00			2		PLATE,HDL RTNG:STAINLESS STEEL	80009	386-1624-00
-5	386-1283-00			2		PLATE,HDL MTG:FRONT - - - * - - -	80009	386-1283-00
-6	124-0293-00			1		STRIP,TRIM:RIGHT	80009	124-0293-00
-7	390-0417-00	B010100	B010799	1		COVER,PWR SPLY:TOP	80009	390-0417-00
	390-0417-01	B010800		1		COVER,PWR SPLY:TOP (ATTACHING PARTS)	80009	390-0417-01
-8	211-0622-00			6		SCREW,MACHINE:6-32 X 0.188,TRH,SST,POZ - - - * - - -	12360	OBD
-9	348-0385-00			2		FOOT,CABINET:SIL GRAY NYLON (ATTACHING PARTS)	80009	348-0385-00
-10	211-0537-00			2		SCREW,MACHINE:6-32 X 0.375 INCH,TRH STL - - - * - - -	83385	OBD
-11	124-0294-00			1		STRIP,TRIM:LEFT	80009	124-0294-00
-12	348-0398-00			1		FLIPSTAND,CAB:	80009	348-0398-00
-13	348-0074-00			2		HINGE BLOCK,STA:R FR,L REAR,BLACK ACETAL (ATTACHING PARTS)	80009	348-0074-00
-14	211-0532-00			4		SCREW,MACHINE:6-32 X 0.75 INCH,FILH STL	83385	OBD
-15	348-0207-00			2		FOOT,CABINET:RIGHT FRONT AND LEFT REAR - - - * - - -	80009	348-0207-00
-16	348-0073-00			2		HINGE BLOCK,STA:L FR,R REAR,BLACK ACETAL (ATTACHING PARTS)	80009	348-0073-00
-17	211-0532-00			4		SCREW,MACHINE:6-32 X 0.75 INCH,FILH STL	83385	OBD
-18	348-0208-00			2		FOOT,CABINET:LEFT FRONT AND RIGHT REAR - - - * - - -	80009	348-0208-00
-19	390-0418-00			1		COVER,PWR SPLY:BOTTOM (ATTACHING PARTS)	80009	390-0418-00
	211-0622-00			2		SCREW,MACHINE:6-32 X 0.188,TRH,SST,POZ - - - * - - -	12360	OBD
-20	390-0443-00			2		COVER,PWR SPLY:TOP & BOTTOM (ATTACHING PARTS)	80009	390-0443-00
-21	211-0502-00			12		SCREW,MACHINE:6-32 X 0.188",FLH STL - - - * - - -	83385	OBD
-22	351-0104-00	B010100	B012479	1		SLIDE SECT,DWR:12.625 X 2.25	06666	C-720-2
	351-0104-03	B012480		1		SLIDE SECT,DWR:12.625 L,W/O HARDWARE (ATTACHING PARTS)	06666	C-720-2
-23	212-0004-00			6		SCREW,MACHINE:8-32 X 0.312 INCH,PNH STL	83385	OBD
-24	210-0858-00			6		WASHER,FLAT:0.500 OD X 0.171 ID X 0.063 THK - - - * - - -	80009	210-0858-00
-25	367-0022-00			2		HANDLE,BOW:1.5 X 4.5 INCH (ATTACHING PARTS)	06540	10353-B-1032-25A
-26	212-0574-00			4		SCREW,MACHINE:10-32 X 0.438"100 DEG FLH STL - - - * - - -	83385	OBD
-27	407-1458-00			2		BRACKET,ANGLE:RACKMOUNT,ALUMINUM (ATTACHING PARTS)	80009	407-1458-00
-28	212-0574-00			4		SCREW,MACHINE:10-32 X 0.438"100 DEG FLH STL - - - * - - -	83385	OBD

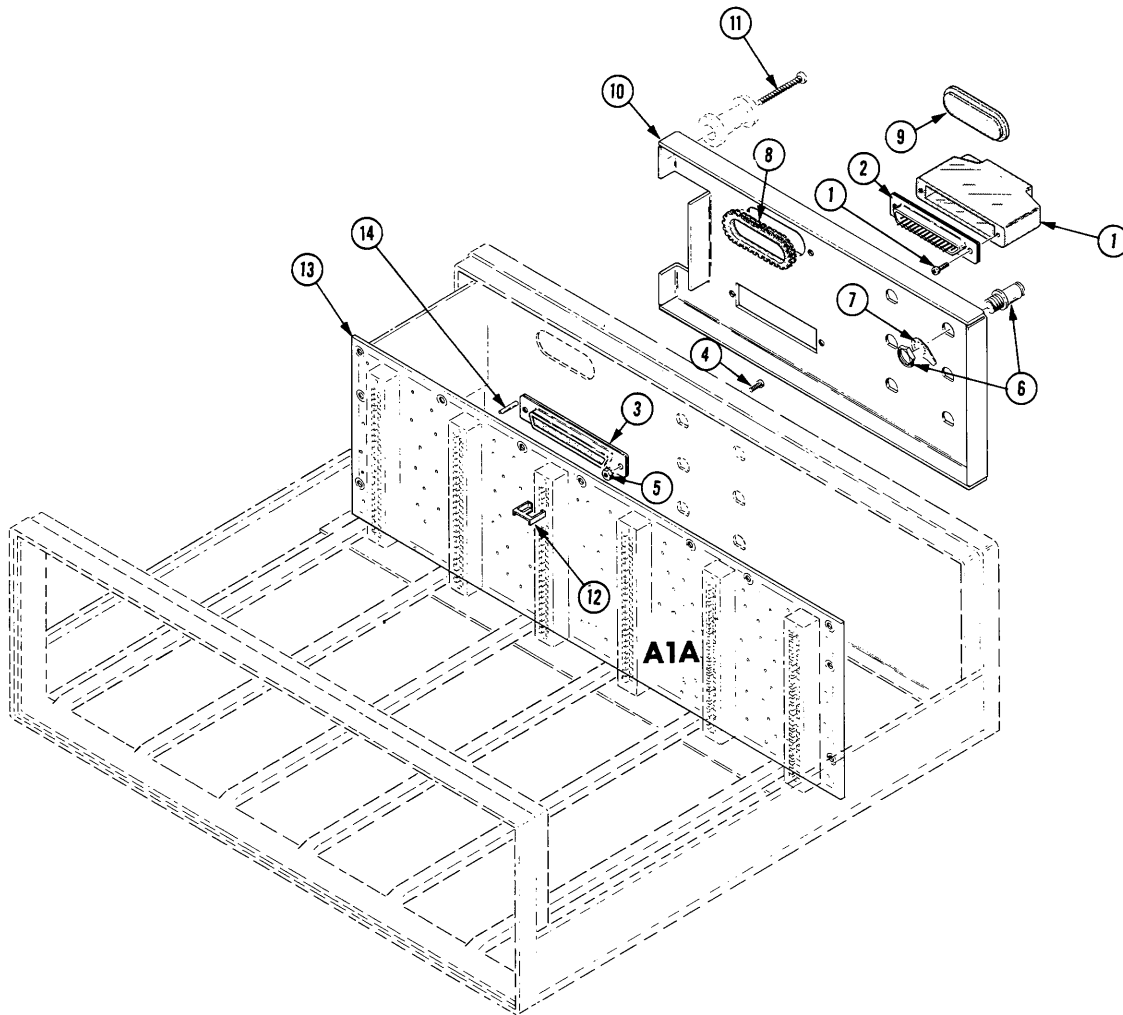

Fig. & Index No.	Tektronix Part No.	Serial/Model No. Eff	Dscont	Qty	1	2	3	4	5	Name & Description	Mfr Code	Mfr Part Number
3-1	131-1319-00			1						COVER,CONN:MOLD PLASTIC W/HARDWARE	08051	DD51216-1
-2	131-1345-00			1						CONNECTOR,RCPT,:50 FEMALE CONTACT	71468	DD-50S
-3	131-1344-00			1						CONNECTOR,PLUG,:50 CONT,MALE D (ATTACHING PARTS)	71468	DD-50P
-4	211-0008-00			2						SCREW,MACHINE:4-40 X 0.25 INCH,PNH STL	83385	OBD
-5	210-0586-00			2						NUT,PLAIN,EXT W:4-40 X 0.25 INCH,STL - - - * - - -	78189	OBD
-6	131-0955-00			6						CONNECTOR,RCPT,:BNC,FEMALE,W/HARDWARE (ATTACHING PARTS)	05091	31-279
-7	210-0255-00			6						TERMINAL,LUG:0.391" ID INT TOOTH - - - * - - -	80009	210-0255-00
-8	255-0334-00			FT						PLASTIC CHANNEL:	11897	122-37-2500
-9	200-1814-00			1						COVER,CONN HOLE:2.1 L X 0.8 W,PLASTIC	80009	200-1814-00
-10	386-3224-00			1						PLATE,CONN MTG: (ATTACHING PARTS)	80009	386-3224-00
-11	212-0102-00			4						SCREW,MACHINE:8-32 X 2 INCH,PNH STL - - - * - - -	76689	OBD
-12	214-1593-02			20						KEY,CONN PLZN:CKT BD CONN	80009	214-1593-02
-13	-----			1						CKT BOARD ASSY:INTERFACE (SEE A1A EPL)		
-14	131-0608-00			316						. CONTACT,ELEC:0.365L X 0.25 PH BRZ GOLD PL (OTHER SUBPARTS SAME AS STANDARD INTER- FACE CIRCUIT BOARD)	22526	47357
	020-0137-00			1						COMPONENT KIT:WIRES AND CONNECTORS	80009	020-0137-00

Fig. & Index No.	Tektronix Part No.	Serial/Model No. Eff      Dscont	Qty	1	2	3	4	5	Name & Description	Mfr Code	Mfr Part Number
	070-1786-02		1						MANUAL, TECH: INSTRUCTION	80009	070-1876-02
	351-0101-00	B010100 B012129	1						SLIDE, DWR, EXT: 18.0 X 1.69	80009	351-0101-00
	-----		-						(RACKMOUNT ONLY)		
	351-0195-00	B012130	1						SLIDE, DWR, EXT: 23.0 L X 1.69	06666	C719
	-----		-						(RACKMOUNT ONLY)		
	200-1728-00		1						COVER, FRONT(OPTIONAL)	80009	200-1728-00

## **MANUAL CHANGE INFORMATION**

At Tektronix, we continually strive to keep up with latest electronic developments by adding circuit and component improvements to our instruments as soon as they are developed and tested.

Sometimes, due to printing and shipping requirements, we can't get these changes immediately into printed manuals. Hence, your manual may contain new change information on following pages.

A single change may affect several sections. Since the change information sheets are carried in the manual until all changes are permanently entered, some duplication may occur. If no such change pages appear following this page, your manual is correct as printed.

## **SERVICE NOTE**

Because of the universal parts procurement problem, some electrical parts in your instrument may be different from those described in the Replaceable Electrical Parts List. The parts used will in no way alter or compromise the performance or reliability of this instrument. They are installed when necessary to ensure prompt delivery to the customer. Order replacement parts from the Replaceable Electrical Parts List.

# CALIBRATION TEST EQUIPMENT REPLACEMENT

## Calibration Test Equipment Chart

This chart compares TM 500 product performance to that of older Tektronix equipment. Only those characteristics where significant specification differences occur, are listed. In some cases the new instrument may not be a total functional replacement. Additional support instrumentation may be needed or a change in calibration procedure may be necessary.

Comparison of Main Characteristics

DM 501 replaces 7D13		
PG 501 replaces 107 108	PG 501 - Risetime less than 3.5 ns into 50 Ω. PG 501 - 5 V output pulse; 3.5 ns Risetime	107 - Risetime less than 3.0 ns into 50 Ω. 108 - 10 V output pulse 1 ns Risetime
PG 502 replaces 107 108 111	PG 502 - 5 V output PG 502 - Risetime less than 1 ns; 10 ns Pretrigger pulse delay	108 - 10 V output 111 - Risetime 0.5 ns; 30 to 250 ns Pretrigger pulse delay
PG 508 replaces 114 115 2101	Performance of replacement equipment is the same or better than equipment being replaced.	
PG 506 replaces 106 067-0502-01	PG 506 - Positive-going trigger output signal at least 1 V; High Amplitude output, 60 V. PG 506 - Does not have chopped feature.	106 - Positive and Negative-going trigger output signal, 50 ns and 1 V; High Amplitude output, 100 V. 0502-01 - Comparator output can be alternately chopped to a reference voltage.
SG 503 replaces 190, 190A, 190B 191 067-0532-01	SG 503 - Amplitude range 5 mV to 5.5 V p-p. SG 503 - Frequency range 250 kHz to 250 MHz.	190B - Amplitude range 40 mV to 10 V p-p. 0532-01 - Frequency range 65 MHz to 500 MHz.
SG 504 replaces 067-0532-01 067-0650-00	SG 504 - Frequency range 245 MHz to 1050 MHz.	0532-01 - Frequency range 65 MHz to 500 MHz.
TG 501 replaces 180, 180A 181 184 2901	TG 501 - Trigger output-slaved to marker output from 5 sec through 100 ns. One time-mark can be generated at a time. TG 501 - Trigger output-slaved to market output from 5 sec through 100 ns. One time-mark can be generated at a time. TG 501 - Trigger output-slaved to marker output from 5 sec through 100 ns. One time-mark can be generated at a time.	180A - Trigger pulses 1, 10, 100 Hz; 1, 10, and 100 kHz. Multiple time-marks can be generated simultaneously. 181 - Multiple time-marks 184 - Separate trigger pulses of 1 and 0.1 sec; 10, 1, and 0.1 ms; 10 and 1 μs. 2901 - Separate trigger pulses, from 5 sec to 0.1 μs. Multiple time-marks can be generated simultaneously.

**NOTE: All TM 500 generator outputs are short-proof. All TM 500 plug-in instruments require TM 500-Series Power Module.**